

UNIVERSIDADE FEDERAL DO PARANÁ  
SETOR DE CIÊNCIAS BIOLÓGICAS  
DEPARTAMENTO DE FARMACOLOGIA

EDMAR MIYOSHI

O HIPOCAMPO DORSAL E O ESTRIADO SÃO NECESSÁRIOS TANTO PARA A  
NAVEGAÇÃO BASEADA EM PISTAS QUANTO PARA A NAVEGAÇÃO  
ESPACIAL NO LABIRINTO AQUÁTICO DE MORRIS

CURITIBA  
2009

# **Livros Grátis**

<http://www.livrosgratis.com.br>

Milhares de livros grátis para download.

EDMAR MIYOSHI

**O HIPOCAMPO DORSAL E O ESTRIADO SÃO NECESSÁRIOS TANTO PARA A  
NAVEGAÇÃO BASEADA EM PISTAS QUANTO PARA A NAVEGAÇÃO  
ESPACIAL NO LABIRINTO AQUÁTICO DE MORRIS**

Tese apresentado ao Curso de Pós-Graduação em Farmacologia, Setor de Ciências Biológicas, Universidade Federal do Paraná, como requisito parcial à obtenção do título de Doutor em Farmacologia.

Orientador: Prof. Dr. Cláudio Da Cunha

CURITIBA  
2009

EDMAR MIYOSHI

**O HIPOCAMPO DORSAL E O ESTRIADO SÃO NECESSÁRIOS TANTO PARA A  
NAVEGAÇÃO BASEADA EM PISTAS QUANTO PARA A NAVEGAÇÃO  
ESPACIAL NO LABIRINTO AQUÁTICO DE MORRIS**

Tese aprovada como requisito parcial para obtenção do grau de Doutor em Farmacologia ao Curso de Pós-Graduação em Farmacologia, Setor de Ciências Biológicas, Universidade Federal do Paraná, pela seguinte banca examinadora:

Orientador: Prof. Dr. Cláudio Da Cunha  
Professor Livre Docente – Universidade Federal do Paraná

Prof. Dr. Marcus Lira Brandão  
Professor Titular – Universidade de São Paulo – Ribeirão Preto

Prof. Dr. Rui Daniel S. Prediger  
Professor Adjunto – Universidade Federal de Santa Catarina

Profa. Dra. Maria Aparecida B. F. Vital  
Professor Associado – Universidade Federal do Paraná

Prof. Dr. Marcelo Machado Ferro  
Professor Adjunto - Universidade Estadual de Ponta Grossa

Curitiba, 09 de outubro de 2009.

Dedico aos meus pais, Masafiro e Matsue,  
pelo grande apoio e incentivo à realização  
deste trabalho.

## AGRADECIMENTOS

A Deus que sempre me guiou pelo caminho da vida, dando saúde e força para eu não desistir mesmo que muitas vezes este caminho tenha sido cheio de obstáculos.

A Ana Paula que teve paciência nos momentos em que não pude estar presente e por suportar a minha impaciência nos momentos em que estive presente. Além disso, pelo grande amor sempre dedicado a mim.

Ao amigo e orientador Cláudio que sempre compartilhou seu vasto conhecimento e permitiu a realização deste trabalho, além da confiança, atenção e amizade em mim depositada.

Aos meus amigos de laboratório, Evellyn, Lucélia, Patrícia, Mariza, Suelen, Marcelo, Jamile e Flávia, pelo auxílio nos experimentos, trocas de informações, pelos problemas e sorrisos compartilhados.

Aos meus amigos, alunos e professores, da Pós-Graduação em Farmacologia pelas conversas agradáveis realizadas no corredor do departamento e pela grande amizade e apoio, tornando a execução deste trabalho muito agradável.

Aos meus colegas, professores e funcionários, da Universidade Estadual de Ponta Grossa pelo apoio à realização deste trabalho que permitiu o afastamento de minhas atividades didáticas.

A todos os meus amigos que me ajudaram nos momentos difíceis.

Aos funcionários do Departamento de Farmacologia da UFPR, Silvia, Lindacir, Nair, Jorge e Erich que me auxiliaram, tanto na parte administrativa quanto na parte técnica, na realização dos experimentos e no cuidado com os animais, além da grande amizade.

A CAPES, CNPq e Fundação Araucária pelo apoio financeiro que permitiu a realização deste trabalho.

Enfim, a todas as pessoas que, de maneira direta ou indireta, contribuíram para a realização deste trabalho.

Muito obrigado a todos!

*"É PRECISO COMEÇAR A PERDER A MEMÓRIA PARA PERCEBER QUE É ELA QUE FAZ A NOSSA VIDA. UMA VIDA SEM MEMÓRIA NÃO SERIA UMA VIDA."*

*LUIS BUÑUEL*

## SUMÁRIO

<b>LISTA DE ABREVIACÕES .....</b>	<b>viii</b>
<b>RESUMO.....</b>	<b>ix</b>
<b>ABSTRACT .....</b>	<b>x</b>
<b>1 INTRODUÇÃO.....</b>	<b>1</b>
1.1 TIPOS DE MEMÓRIA.....	1
<b>2 OBJETIVO GERAL .....</b>	<b>12</b>
2.1 OBJETIVOS ESPECÍFICOS .....	12
2.1.1 <i>Objetivo 1</i> .....	12
2.1.2 <i>Objetivo 2</i> .....	12
2.1.3 <i>Objetivo 3</i> .....	12
<b>3 ARTIGO .....</b>	<b>13</b>
<b>4 DISCUSSÃO .....</b>	<b>47</b>
<b>5 CONCLUSÕES.....</b>	<b>51</b>
<b>REFERÊNCIAS BIBLIOGRÁFICAS .....</b>	<b>52</b>
<b>ANEXOS .....</b>	<b>56</b>
ANEXO 1 .....	57
ANEXO 2 .....	80



## LISTA DE ABREVIACOES

- DLS - estriado dorsolateral (do ingls *dorsolateral striatum*)
- DMS - estriado dorsomedial (do ingls *dorsomedial striatum*)
- R-O - resposta-consequncia (do ingls *response-outcome*)
- SNc - substncia negra *pars compacta*
- S-R - memria estmulo-resposta (do ingls *stimulus-response*)
- S-R-O - memria estmulo-resposta-consequncia (do ingls *stimulus-response-outcome*)
- S-S - memria estmulo-estmulo (do ingls *stimulus-stimulus*)

## RESUMO

Nesta tese buscamos explicar o papel do hipocampo dorsal e do estriado dorsolateral e a interação entre eles na navegação em um labirinto aquático. Dados na literatura têm mostrado a dissociação entre estas duas estruturas no aprendizado e na memória. Onde, o hipocampo dorsal é importante para desempenhar a versão espacial, mas não a versão com pista visual, do labirinto aquático. Enquanto que o estriado é importante para a versão com pista visual, mas não para a versão espacial. Entretanto, vários trabalhos mostram que estes sistemas não trabalham de forma isolada, eles podem interagir entre si. A natureza desta interação ainda é bastante controversa. Para contribuir na solução desta controvérsia, avaliamos a interação entre o estriado dorsolateral e o hipocampo no aprendizado em tarefas do labirinto aquático. Para isto, submetemos animais com lesões isoladas do estriado dorsolateral ou hipocampo e animais com lesões das duas estruturas em diferentes versões do labirinto aquático: com pista visual ou espacial, dependentes do estriado dorsolateral ou hipocampo respectivamente. Animais com lesões isoladas no hipocampo apresentaram um prejuízo no aprendizado da versão espacial, mas não na versão com pista visual do labirinto aquático. Mas, todos os animais conseguiram aprender a tarefa com mais sessões de treinamento. Os animais com lesão no estriado dorsolateral aprenderam as duas versões como os animais controle. Quando os animais foram pré-treinados em uma das versões e testados na outra versão, i.e. pré-treinados na versão com pista visual e testados na versão espacial e vice-versa, não foi observado este prejuízo. Entretanto, aqueles animais com lesão dupla (do estriado dorsolateral e do hipocampo) apresentaram um prejuízo severo em ambas as versões, tal como se não apresentassem nenhuma evidência de aprendizado e estes prejuízos não desapareceram ao longo das sessões de treinamento e nem com o pré-treinamento em outra versão. Estes resultados sugerem que tanto o estriado dorsolateral como o hipocampo dorsal são necessários para os dois tipos de aprendizados, contrariando a teoria vigente na literatura de que há uma dupla dissociação: versão espacial dependente do hipocampo, mas não do estriado e versão com pista visual dependente do estriado (dorsolateral) e não do hipocampo. Isto sugere que estes dois sistemas não só atuam de forma cooperativa, como que eles desempenham papéis complementares essenciais para a navegação e aprendizado espacial. As implicações destes resultados para o modelo do mosaico dos espelhos quebrados também é discutido nesta tese.

## ABSTRACT

In this thesis we proposed an explanation for the role of the dorsal hippocampus and of the dorsolateral striatum and the interaction between them in the navigation in water maze task. Data in the literature have been showing the double dissociation between these structures in the learning and memory. Where, the dorsal hippocampus is important to perform the spatial version, but not the cued version, of the water maze task. While striatum is important for the cued version, but not for the spatial version. However, several works showed that these systems didn't work in an isolated way, they can interact between them. The nature of this interaction is still controversial. In order to contribute with a solution for this controversy, we evaluated the interaction between dorsolateral striatum and the hippocampus in the learning of water maze task. For this, we submitted animals with isolated lesions on the dorsolateral striatum or hippocampus and animals with lesions of both structures in different versions of the water maze: cued or spatial, dorsolateral striatum- or hippocampus-dependent, respectively. Animals with isolated lesions in the hippocampus showed impairment in the spatial version, but not in the cued version of the water maze task. But, all the animals learned this task when submitted to more training sessions. The animals with lesion in the dorsolateral striatum learned the two versions as the control animals. When the animals were pre-trained in one of the versions and tested in the other version, i.e. pretrained in the cued version and tested in the spatial version and vice-versa, this damage was not observed. However, those animals with double lesion (dorsolateral striatum and hippocampus) presented a severe impairment in both versions, as if they didn't present any learning evidence and this impairment didn't disappear along the training sessions nor with the pre-training in another version. These results suggest that both dorsolateral striatum and dorsal hippocampus are necessary for the two types of learning, contradicting the current theory in the literature that there is a double dissociation: spatial version dependent of the hippocampus but not of the striatum and cued version dependent of the striatum (dorsolateral) and not of the hippocampus. This suggests that these two systems not only interact in a cooperative way, but they play a complementary role, that is essential for the navigation and spatial learning. The implications of these results for the mosaic of broken mirrors model are also discussed in this thesis.

## 1 INTRODUÇÃO

A organização da memória no cérebro dos mamíferos e os sistemas neurais que medeiam os processos de aprendizado e memória têm um papel importante nos nossos pensamentos, emoções, escolhas, ações e personalidade. Perder a memória leva à perda de si mesmo, à perda da história de uma vida e das interações duradouras com outros seres humanos. O enfraquecimento normal da memória com a idade e o prejuízo causado pelas doenças de Alzheimer, Parkinson e Huntington são apenas os exemplos mais conhecidos de um grande número de doenças que afetam a memória.

Durante muito tempo debateu-se intensamente a possibilidade de a memória ser considerada uma função unitária ou ser decomposta em diferentes sistemas. Rejeitada de início pelos cientistas, a idéia de que podem existir várias formas ou tipos de memória hoje afinal se impôs (Poldrack e Packard, 2003; Squire, 2004; Squire, Stark et al., 2004; Voermans, Petersson et al., 2004; Doeller, King et al., 2008; Lee, Duman et al., 2008; Berke, Breck et al., 2009). Esta hipótese dos vários tipos de memória recebeu um importante apoio com o estudo de Scoville e Milner em 1957 (Scoville e Milner, 1957). Estes autores estudaram o paciente H.M., um homem que se tornou amnésico após a retirada cirúrgica do seu lobo temporal medial para melhorar suas crises epiléticas. H.M. apresentou um prejuízo em algumas tarefas de memória (principalmente as memórias episódica), entretanto, ele ainda conseguia aprender certas tarefas (traçar o contorno de uma estrela olhando por um espelho), sugerindo que existiria outro tipo de memória.

### 1.1 TIPOS DE MEMÓRIA

Existem várias classificações diferentes para as memórias. Uma dessas classificações

que podem ser encontrada é a seguida por Izquierdo (Izquierdo, 2002), onde ele classifica as memórias quanto ao tempo de duração em:

- Memória de longa duração - é aquela que dura muitas horas, dias ou anos;
- Memória de curta duração - é o processo ou conjunto de processos que mantém a memória funcionando durante estas horas iniciais em que a memória de longa duração ainda não assumiu sua forma definitiva; e,
- Memória operacional (“working memory”) - que mantém a informação “viva” durante segundos ou poucos minutos, enquanto ela está sendo percebida conscientemente ou processada em uma operação mental.

Além dessa classificação, as memórias de longa duração podem ser subdivididas em dois grandes grupos de memória (figura 1) (Salmon e Butters, 1995; Izquierdo, 2002; Squire, 2004):

#### 1) as memórias declarativas ou explícitas

São aquelas que nós humanos podemos relatar e evocar de forma consciente. Elas guardam informações factuais sobre eventos que vivenciamos no passado. Este tipo de memória pode ser também subdividido em: memória episódica (representações de experiências pessoais específicas que ocorreram em um contexto de tempo e espaço – saber o que, onde e quando) e memória semântica (conjunto de conhecimentos generalizados sobre o mundo sem nenhuma vinculação com uma experiência pessoal específica).

2) as memórias não-declarativas ou implícitas

São aquelas que podemos adquirir e evocar de forma automática ou inconsciente. Este tipo de memória pode ser subdividido em: memória de procedimento, o *priming* (aperfeiçoamento da capacidade de detectar ou identificar palavras ou objetos após uma experiência recente com eles), o condicionamento e memórias formadas por aprendizado não-associativo (habituação e sensibilização).



FIGURA 1 – ESQUEMA DA CLASSIFICAÇÃO DA MEMÓRIA DE LONGA DURAÇÃO E AS ESTRUTURAS CEREBRAIS IMPORTANTES PARA CADA TIPO DE MEMÓRIA.

**FONTE:** modificado de SQUIRE, L.R. Memory systems of the brain: a brief and current perspective. *Neurobiology of Learning and Memory*. v. 82, p. 171-177, 2004.

Vários autores sugerem que estes diferentes grupos de memórias sejam organizados e controlados por sistemas neuroanatômicos distintos (Packard e White, 1990; Packard e Mcgaugh, 1992; McDonald e White, 1994; Salmon e Butters, 1995; Oliveira, Bueno et al., 1997; Packard e Teather, 1997; 1998; Eichenbaum, 2004; Squire, 2004; Doeller, King et al.,

2008; Lee, Duman et al., 2008; Berke, Breck et al., 2009). Dois exemplos bem definidos destes sistemas de memória são: o sistema de memória declarativa, o qual tem o hipocampo como estrutura central (Eichenbaum, 2004; Squire, 2004; Gold e Squire, 2006; Squire, 2009), e o sistema de memória de procedimento, o qual tem os gânglios da base como núcleo central (Knowlton, Mangels *et al.*, 1996; Da Cunha, Gevaerd *et al.*, 2001; Miyoshi, Wietzikoski *et al.*, 2002; Packard e Knowlton, 2002; Da Cunha, Wietzikoski *et al.*, 2003; Da Cunha, Silva *et al.*, 2006; Prediger, Batista *et al.*, 2006; Da Cunha, Wietzikoski *et al.*, 2007; Da Cunha, Wietzikoski *et al.*, 2009; Prediger, Rial *et al.*, 2009).

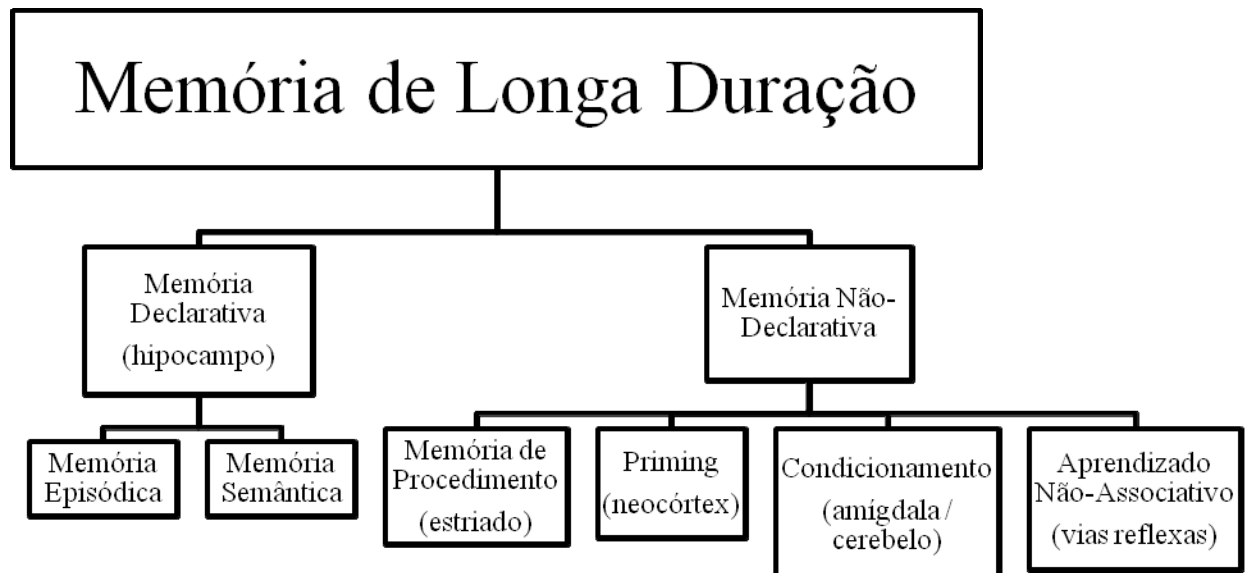
Em humanos, a memória declarativa episódica é sempre expressa na forma de recordações conscientes de experiências pessoais específicas (o sujeito dentro de um contexto espacial e temporal). Como os animais não possuem uma linguagem equivalente à de humanos, estas propriedades (ser declarativa e consciente) não podem ser estudadas em modelos animais. Entretanto, a memória declarativa humana tem diversas outras propriedades além da lembrança consciente e declarativa, podendo, muitas delas, serem estudadas.

Por exemplo, a memória declarativa é elaborada para representar objetos e eventos no mundo externo e as relações (espaciais, temporais e lógicas) entre eles. Esta organização associativa das memórias declarativas resulta em uma representação flexível (relacional) do espaço e do tempo. Animais podem aprender relações entre itens armazenados e, então, ter sua memória episódica testada em situações onde precisem usar estas relações de forma flexível para resolver uma tarefa de aprendizagem e memória (Eichenbaum, 2004).

Já a memória de procedimento foi sempre fácil de entender intuitivamente com algo especial, diferente da evocação comum de eventos recentes. Eles não são declarativos: não precisamos “declarar” coisa alguma nem ser capazes de, mesmo quando pressionados, dizer muito sobre o que estamos fazendo. Adquirimos muitos hábitos e habilidades no início da vida, sem esforço óbvio e sem observarmos o momento em que tal aprendizado ocorreu.

Um modo de se estudar este tipo de memória em animais é expondo-os a uma tarefa onde o animal, a partir de um determinado estímulo, deve exercer uma determinada resposta para obter reforço. Este é um tipo de aprendizado é chamado de estímulo-resposta-consequência (S-R-O).

Na formação de memórias resposta-consequência (R-O) ou ação-consequência (*action-outcome*), o sujeito aprende que uma ação ou resposta têm como consequência um estímulo (incondicionado) cuja percepção envolve uma avaliação hedônica de “recompensador” ou “aversivo”. Na linguagem da psicologia experimental, o pareamento de um estímulo reforçador, subsequente a uma resposta do sujeito resulta em uma maior probabilidade de que ele emita esta resposta no futuro. Ainda segundo esta corrente teórica, a apresentação de um estímulo punidor, subsequente a uma resposta, diminui a probabilidade de que esta resposta seja emitida no futuro. Porém, se após a aprendizagem, a consequência reforçadora ou punidora não ocorrer, esta memória entra em processo de extinção (Yin e Knowlton, 2006; Balleine, Liljeholm *et al.*, 2009).

Já na formação da memória de hábito, um estímulo (condicionado) é repetidamente pareado com uma resposta incondicionada, i.e. que é emitida de forma inata pelo sujeito em reação ao estímulo (Thorndike, 1911; Hull, 1943). Ainda há muita divergência sobre a natureza desta memória.

Nos primórdios da psicologia comportamental, este tipo de aprendizagem era chamado de “controle por estímulo” e dizia-se que o que é aprendido é a associação entre o estímulo condicionado e a resposta incondicionada, daí o nome de hábito estímulo-resposta (S-R). Já os teóricos modernos, tais como o americano Balleine, dizem que a formação do hábito é uma decorrência de um aprendizado instrumental muito prolongado (onde se parecia resposta e consequência).

Segundo Balleine, em situações onde as consequências de uma resposta a um



estímulo não mudam, a repetição deste pareamento S-R-O leva a uma automação da resposta, de forma que o indivíduo a escolhe e executa de forma automática. Após um treino extensivo, a resposta (ação/comportamento) deixa de ser controlada pela consequência e passa a ser controlada pelo estímulo condicionado (S-R) (Balleine, Liljeholm *et al.*, 2009).

Um exemplo de experimento que pode ser utilizado para avaliar estes tipos de memórias é o labirinto aquático de Morris. Esta tarefa do labirinto aquático foi desenvolvida por Richard Morris em 1982 e consiste em colocar o animal em uma piscina circular com água. Em algum lugar da piscina havia uma plataforma que permanecia logo abaixo do nível da água (invisível para o rato).

Os ratos nadavam muito bem, mas preferiam subir na plataforma para fugir da água. Subir na plataforma era uma recompensa eficiente, chamada na psicologia comportamental de reforço negativo. Em cada tentativa, o animal foi colocado em pontos diferentes da borda da piscina. Os ratos aprenderam a usar uma estratégia espacial (relação entre as pistas localizadas fora do labirinto) para encontrar a plataforma. Isto pode ser observado pela redução na latência para encontrar a plataforma.

Morris e seus colaboradores demonstraram que a lesão do hipocampo causa um prejuízo no desempenho desta tarefa (Morris, Garrud *et al.*, 1982). A partir deste trabalho de Morris e colaboradores, esta tarefa do labirinto aquático passou a ser bastante útil para a pesquisa de aprendizado e memória em animais. Isto pode ser observado através de uma pesquisa no site da “*Web of Science*” com as seguintes palavras chaves: “Morris water maze” AND (learning OR memory) no período de 1982 até 2009. Realizando esta busca, encontramos 3014 artigos com estas características (pesquisa realizada no dia 16 de setembro de 2009).

A flexibilidade da memória episódica e a relativa inflexibilidade de memórias não-declarativas são vivamente ilustradas em um estudo sobre aprendizado e memória espacial em

ratos. Eichenbaum e colaboradores (Eichenbaum, Stewart et al., 1990) avaliaram o desempenho de animais com lesão hipocampal em uma versão modificada do labirinto aquático de Morris.

Neste estudo os animais foram liberados para nadar somente de um ponto de partida e deveriam encontrar a plataforma submersa oculta. Tanto os animais com lesão hipocampal como os animais controle aprenderam a localização da plataforma submersa, conforme avaliado por reduções marcantes no tempo de natação e na distância percorrida até atingir a plataforma. Assim, à medida que o aprendizado progredia, os ratos aprendiam a nadar diretamente até a plataforma. Depois de completar-se o aprendizado, os animais foram submetidos a testes adicionais para que se determinasse que tipo de informação haviam adquirido sobre a localização da plataforma.

Nessas sessões, os ratos eram liberados de um novo ponto de partida. Os animais intactos eram capazes de descobrir a plataforma rapidamente a partir de qualquer ponto inicial, indicando que haviam adquirido uma representação flexível (declarativa) do espaço na memória. Mais especificamente, eles haviam aprendido sobre as relações espaciais entre a localização da plataforma e as várias dicas externas que estavam disponíveis nas paredes que circundavam o tanque (mapa relacional).

Este tipo de aprendizado foi classificado por White como sendo do tipo estímulo-estímulo (S-S). Em contraste, os ratos com lesões hipocampais eram incapazes de encontrar a plataforma a partir de novos pontos de partida e tinham de recomeçar a busca empregando uma estratégia do tipo tentativa-e-erro ao longo do labirinto.

Estudos posteriores mostraram que o aprendizado espacial em ratos depende criticamente da integridade do hipocampo, mas não do estriado (Packard e Mcgaugh, 1992; White e McDonald, 2002; Da Cunha, Wietzikoski et al., 2007; Goodrich-Hunsaker, Livingstone et al., 2009; Xavier e Costa, 2009).

Resultados semelhantes foram obtidos por Da CUNHA e colaboradores (Da Cunha, Wietzikoski et al., 2003) através da administração de lidocaína no hipocampo dorsal de ratos submetidos à versão espacial (S-S) da tarefa do labirinto aquático. Os animais inicialmente aprenderam a encontrar a plataforma submersa, pois o tempo de latência para encontrá-la diminuiu. Entretanto, a administração de lidocaína intra-hipocampal, antes da exposição ao labirinto, promoveu um aumento no tempo de latência, sugerindo um prejuízo na memória espacial (S-S).

Outro trabalho que usou estas versões do labirinto aquático de Morris foi realizado por PACKARD e McGAUGH (Packard e Mcgaugh, 1992). Eles mostraram que animais com lesão do estriado dorsal conseguem aprender a desempenhar a versão espacial (S-S) da tarefa do labirinto aquático. Mas estes animais têm um prejuízo na versão com pista visual (S-R-O) da tarefa do labirinto aquático (Packard e Mcgaugh, 1992). Nesta versão, o animal deve encontrar uma plataforma que possui uma pista visual sobre ela e visível ao animal, mas sua posição se altera entre uma tentativa e outra.

Então, o estriado é visto como uma região importante para o aprendizado de relações entre um único estímulo e uma resposta recompensada, ou seja, aprendizado S-R-O (White e Mcdonald, 2002). Há evidências de que ocorra uma dissociação entre o estriado dorsolateral (DLS, equivalente ao putamen de primatas) e o estriado dorsomedial (DMS, equivalente ao núcleo caudado em primatas), onde o primeiro seria importante para o aprendizado S-R-O (Devan, Mcdonald *et al.*, 1999) e o último para o aprendizado espacial (S-S) (White, 2009).

Outros estudos também mostraram esta dissociação entre o sistema hipocampal (memória declarativa) e o sistema dos gânglios da base (memória de procedimento), como por exemplo um importante estudo realizado por PACKARD e colaboradores (Packard, Hirsh et al., 1989). Eles treinaram ratos para realizar duas tarefas diferentes, que mostravam diferenças chave entre a memória de hábito e a memória declarativa episódica. Em uma tarefa, os

animais deveriam procurar por alimento nos oito braços de um labirinto radial. A cada dia, durante diversos dias, os ratos eram colocados no labirinto e, após, retirados quando tivessem recolhido uma recompensa de cada um dos oito braços do labirinto. Um erro era registrado cada vez que o animal entrasse pela segunda vez em um braço no curso da coleta das oito recompensas. O desempenho nessa tarefa de memória é prejudicado por lesão do sistema hipocampal, porém, a lesão do estriado dorsal não tem efeito. Em uma tarefa semelhante que utilizou o mesmo labirinto, os animais aprenderam a visitar quatro dos oito braços, os quais eram sinalizados, através de uma luz, que continham o alimento como recompensa. Após duas semanas de treino, os animais gradualmente aprenderam a entrar nos braços corretos. Nessa tarefa, onde o animal deveria associar o estímulo (luz) com a resposta recompensada (entrar para comer o alimento) o aprendizado foi prejudicado por lesão do estriado dorsal, mas não por lesão do sistema hipocampal.

Algum tempo depois, um questionamento que começou a ser feito foi se estes sistemas funcionavam de forma isolada ou eles poderiam interagir entre si? E, nas últimas cinco décadas, pesquisadores têm focado seus estudos na dissociação entre os sistemas de memórias e suas funções no armazenamento de informações e adaptação do comportamento (Scoville e Milner, 1957; Packard e White, 1990; Packard e Mcgaugh, 1992; McDonald e White, 1994; Packard e Teather, 1997; 1998; Miyoshi, Wietzikoski et al., 2002; Da Cunha, Silva et al., 2006; Doeller, King et al., 2008).

Entretanto, pode ser que os sistemas de memória trabalhem de uma forma integrada, e não de forma isolada (White e McDonald, 2002; Voermans, Petersson et al., 2004; Hartley e Burgess, 2005; Albouy, Sterpenich et al., 2008; Doeller, King et al., 2008; Lee, Duman et al., 2008; Berke, Breck et al., 2009).

A maioria destes estudos observou o prejuízo causado pela lesão de uma estrutura cerebral no desempenho de tarefas (Da Cunha, Gevaerd et al., 2001; Da Cunha, Angelucci et

al., 2002; Da Cunha, Wietzikoski et al., 2003; McDonald, Hong et al., 2004). E, quando uma lesão de determinada estrutura prejudicava o desempenho de determinada tarefa, concluíam que aquela estrutura era importante para aquele tipo de aprendizado e memória. Por exemplo, concluiu-se que a SNc é importante para a memória S-R-O e operacional (mas não para a memória espacial) porque sua lesão causou um prejuízo no desempenho da versão com pista visual e na versão da memória espacial operacional do labirinto aquático de Morris e não prejudicou o desempenho na versão espacial (Miyoshi, Wietzikoski et al., 2002). Mas, estudos recentes sugerem que ocorre uma interação (competição e/ou cooperação) entre os diferentes sistemas neurais de memória (Poldrack e Packard, 2003; Voermans, Petersson et al., 2004; Albouy, Sterpenich et al., 2008; Lee, Duman et al., 2008; Berke, Breck et al., 2009).

A interação competitiva entre os sistemas de memória pode ser revelada pelos estudos em que a lesão de um dado sistema resulta em melhora na aprendizagem da tarefa dependente da estrutura encefálica intacta (Poldrack e Packard, 2003). Por exemplo, animais com lesão do hipocampo dorsal têm um desempenho melhor do que animais controles na tarefa de esquiva de duas vias (dependente do estriado e da SNc) (Guillazo-Blanch, Nadal *et al.*, 2002; Torras-Garcia, Costa-Miserachs *et al.*, 2003).

A interação cooperativa entre os sistemas de memória foi observada por Voermans e colaboradores (Voermans, Petersson et al., 2004) através de um estudo de neuroimagens em pacientes com doença de Huntington desempenhando uma tarefa de memória de navegação espacial. Nesta tarefa, o participante navega em uma sequência de vídeos com uma visão em primeira pessoa. Durante a fase de aquisição, o vídeo é parado em cinco pontos de decisão, que são locais onde o participante deve escolher uma direção (esquerda ou direita) e esta direção é indicada por setas. Os participantes devem lembrar a direção a ser seguida em cada ponto de decisão. Durante a fase de navegação, o participante vê a mesma sequência e deve indicar a direção a ser seguida em cada ponto de decisão (sem auxílio das setas). Esta

tarefa emprega um sistema que adquire gradualmente sequências de resposta para determinada situação (i.e. seguir uma rota fixa repetidamente, S-R-O) e é dependente do estriado. Os pacientes com doença de Huntington que estavam no estágio leve a moderado tinham grande ativação do estriado durante a realização da tarefa, enquanto que os pacientes nos estágios mais graves apresentaram maior ativação do hipocampo. Os pacientes apresentaram escores semelhantes ao do grupo controle na realização desta tarefa, sugerindo uma compensação hipocampal para desempenhar a tarefa.

Dados de nosso laboratório também sugerem uma interação cooperativa, onde os animais com lesão da SNc que são previamente treinados na versão espacial (S-S) do labirinto aquático (dependente do hipocampo) não tem prejuízo em desempenhar a versão com pista visual (S-R-O, dependente dos gânglios da base) (Da Cunha, Wietzikoski et al., 2007). Isto mostra a necessidade de se estudar mais sobre a função do hipocampo e dos gânglios da base nos processos de aprendizado e memória e as interações que ocorrem entre estas estruturas.

## **2 OBJETIVO GERAL**

Avaliar a interação entre os sistemas dos gânglios da base e do hipocampo na navegação em um labirinto aquático.

### **2.1 OBJETIVOS ESPECÍFICOS**

#### **2.1.1 Objetivo 1**

Avaliar o papel do DLS no aprendizado da versão com pista visual do labirinto aquático de Morris, um modelo animal de memória de procedimento (S-R-O).

#### **2.1.2 Objetivo 2**

Avaliar o papel do hipocampo dorsal no aprendizado da versão espacial do labirinto aquático de Morris, um modelo animal de memória relacional (S-S).

#### **2.1.3 Objetivo 3**

Avaliar a interação entre o DLS e o hipocampo dorsal no aprendizado das versões com pista visual e espacial do labirinto aquático de Morris.

### **3 ARTIGO**

Neste trabalho avaliamos o papel do hipocampo, do estriado dorsolateral e da interação entre eles nos processos de aprendizado e memória. O manuscrito deste trabalho foi submetido à revista “HIPPOCAMPUS” neste ano de 2009. Neste estudo apresentamos resultados obtidos de animais com lesão do estriado dorsolateral e/ou do hipocampo submetidos a diferentes versões (dependentes do estriado ou do hipocampo) do labirinto aquático.



1  
2  
3 **Both the dorsal hippocampus and the dorsolateral striatum are needed for**  
4 **rat navigation in the Morris water maze**  
5  
6  
7

8 Edmar Miyoshi<sup>a,b</sup>, Evellyn Claudia Wietzikoski<sup>a,c</sup>, Mariza Bortolanza<sup>a</sup>, Suelen  
9 Lucio Boschen<sup>a</sup>, Newton Sabino Canteras<sup>d</sup>, and Claudio Da Cunha<sup>a,\*</sup>  
10  
11

12  
13  
14 <sup>a</sup>Laboratório de Fisiologia e Farmacologia do Sistema Nervoso Central,  
15 Departamento de Farmacologia, UFPR, Curitiba, Brazil; <sup>b</sup>Departamento de  
16 Ciências Farmacêuticas, UEPG, Ponta Grossa, Brazil. <sup>c</sup>Laboratório de  
17 Neurociências, UNIPAR, Francisco Beltrão, Brazil. <sup>d</sup>Departamento de  
18 Anatomia, Instituto de Ciências Biomédicas-3, USP, São Paulo, Brazil.  
19  
20  
21  
22  
23

24 Running title: The role of the hippocampus and striatum in navigation  
25  
26  
27

28 Number of text pages: 26  
29

30 Number of figures: 7  
31

32 Number of tables: 0  
33

34 **\* Author for correspondence:** Claudio Da Cunha, Laboratório de Fisiologia e  
35 Farmacologia do Sistema Nervoso Central, Departamento de Farmacologia,  
36 UFPR, C.P. 19.031, 81.531-980 Curitiba PR, Brazil. Tel: +55 41 3361-1717.  
37  
38 Fax: +55 41 3266-2042. E-mail: dacunha@pq.cnpq.br  
39  
40  
41

42  
43 Grant sponsors: CNPq, CAPES, Fundação Araucária, FAPESP  
44  
45

46  
47 KEY WORDS: basal ganglia, dopamine, memory, spatial learning, cued  
48 learning  
49  
50  
51  
52  
53  
54  
55  
56  
57  
58  
59  
60

**ABSTRACT**

The multiple memory systems theory proposes that the hippocampus and the dorsolateral striatum are the core structures of the spatial/relational and stimulus-response (S-R) memory systems, respectively. This theory is supported by double dissociation studies showing that the spatial and cued (stimulus-response) versions of the Morris water maze are impaired by lesions in the dorsal hippocampus and dorsal striatum, respectively. In the present study we further investigated this hypothesis by testing whether adult male Wistar rats bearing double and bilateral electrolytic lesions in the dorsal hippocampus and dorsolateral striatum were as impaired as rats bearing single lesions in just one of these structures in learning both versions of the water maze. Such prediction, based on the multiple memory systems theory, was not confirmed by our findings. Although, compared to the controls, the latency to find the escape platform of the animals with single lesions decreased more slowly in one of the versions, the animals with double lesions presented no improvement at all in both versions of the water maze. These results suggest that both the dorsal hippocampus and the dorsolateral striatum are needed for learning cue- and spatial-based navigation in the water maze. Therefore, it seems that, instead of independent systems supporting S-R or spatial learning, the hippocampus and dorsal striatum play critical roles in these two kinds of learning.

## INTRODUCTION

In the recent past the hippocampus was taken as the brain structure playing the main role in spatial navigation learning and performance. Contributed to this reputation the discovery of the hippocampal place cells, neurons that discharge when the animal is in a particular place of the environment (Nadel and O'Keefe, 1978). The finding that rats bearing lesions in the hippocampus are impaired to learn the Morris water maze task, also caused a great impact and made this memory task to be considered a "gold standard" test of the hippocampal function and as a model of spatial/relational memory (Morris et al., 1982; Eichenbaum, 2002; Squire et al., 2004).

Nowadays, navigation learning and performance is seen as the result of computations that involve not only the hippocampus, but also other brain structures. An influential model proposes that the representation of the environment and its reconstitution in the brain is based on a process called pattern integration that points out the location of the animal based on its own movements. According to this theory, an allocentric parahippocampal representation of the environment is translated into an egocentric medial parietal representation (Byrne et al., 2007). This process also depends on the posterior parietal cortex and the retrosplenial cortex/parieto-occipital sulcus (Bird and Burgess, 2008). Still according to this view, in addition to the hippocampal place cells, pattern integration depends on the so called grid cells of the enthorhinal cortex and on the head direction cells found along the Papez's circuit (Hafting et al., 2005; Bird and Burgess, 2008).

The striatum is not usually seen as playing a role in spatial navigation. Contributed to this view, the seminal double dissociation studies reporting that the lesion of the fimbria/fornix, but not of the dorsal striatum, impaired rats to learn the spatial version of the Morris water maze and of the win-shift (spatial) version of the 8-arm radial maze tasks, while lesions of the dorsal striatum, but not of the fimbria/fornix, impaired learning of cued versions of these tasks (Packard et al., 1989; Packard and McGaugh, 1992; McDonald and White, 1994). In order to explain these findings, some authors proposed that both the hippocampus and the striatum can hold control over navigation by using different strategies, and that in some instances they compete for the control

1  
2  
3 over behavior (White and McDonald, 2002; Chavarriaga et al., 2005; Lee et al.,  
4 2008; Berke et al., 2009). According to them, the hippocampus uses the  
5 relations among environmental stimuli to form a kind of “cognitive map”, as  
6 proposed by Tolman (1948) and supported by the hippocampal place cells  
7 (O'keefe and Nadel, 1978), and uses it to plan flexible navigation strategies  
8 (White and McDonald, 2002). The striatum, on its turn, learns the relations  
9 between single environmental stimulus and rewarded responses and thus, can  
10 guide navigation by approaching a specific individual cue that signalizes a  
11 rewarding outcome (White and McDonald, 2002). These two strategies are  
12 sometimes referred to as spatial (or S-S, stimulus-stimulus) and cue-based (or  
13 S-R, stimulus-response) navigation, respectively.

14 Thus, this theory proposes that navigational behavior can be controlled  
15 by two parallel memory systems that sometimes compete for control over  
16 behavior: the hippocampal system mediating spatial/relational navigation and  
17 the striatal system mediating cue-based navigation. However, some years after  
18 this theory was proposed (see White and McDonald, 2002), another study  
19 presented evidence that at least the dorsal medial part of the striatum (DMS) is  
20 also needed for spatial learning (Devan et al., 1999). Then, the  
21 hippocampal/striatal parallel memory systems theory was modified to  
22 incorporate the DMS into the hippocampal-based spatial memory system and  
23 restricted the memory system that supports the cue-based navigation learning  
24 to the dorsolateral striatum (DLS) (White, 2009).

25 Some authors claim that a differential pattern of striatal inputs of the  
26 DMS and DLS may allow them to play different roles in navigation: that the  
27 inputs from the prefrontal cortex and hippocampus to the DMS may enable it to  
28 elaborate flexible navigation strategies based on spatial/contextual information  
29 and the inputs from the sensorymotor cortex to the DLS may enable it to  
30 elaborate rigid and egocentric/cue-based strategies (Potegal et al., 1971;  
31 Veening et al., 1980; McGeorge and Faull, 1989; Ramanathan et al., 2002;  
32 Voorn et al., 2004). However, a recent study by Cenquizca and Swanson (2007)  
33 showed that most projections from the rat field  
34 CA1 to the caudate-putamen are indirect, mediated by the prefrontal cortex, and  
35 is virtually impossible to differentiate between projections to the DMS or  
36 DLS.

1  
2  
3  
4  
5  
6  
7  
8  
9  
10  
11  
12  
13  
14  
15  
16  
17  
18  
19  
20  
21  
22  
23  
24  
25  
26  
27  
28  
29  
30  
31  
32  
33  
34  
35  
36  
37  
38  
39  
40  
41  
42  
43  
44  
45  
46  
47  
48  
49  
50  
51  
52  
53  
54  
55  
56  
57  
58  
59  
60

Defining insensibility to reward devaluation as a feature that distinguishes S-R habits and response-outcome (R-O) behaviors, Balleine, Knowlton, Yin, and co-workers presented the following evidence that these kinds of learning are mediated by the DLS and DMS, respectively: Overtraining and interval schedules of reinforcement are known to convert instrumental R-O responding into S-R habits (Yin and Knowlton, 2006; Balleine et al., 2009). In a study by Yin et al. (2004), lesions in the rat DLS reversed this effect of the overtraining, thus turning habitual into R-O responding. In addition, the inactivation of the DLS of rats enhanced the sensitivity of their instrumental responding to the omission of a rewarding outcome (Yin et al., 2006). Conversely, inactivating the posterior DMS, but not the DLS, of rats prevented the decrease of instrumental responding contingent of the devaluation of a rewarding outcome (Yin et al., 2005) and the discrimination of two stimuli that differentially signaled reinforcement for response to one or the other of two bars (Balleine et al., 2009).

All these findings strengthen the hypothesis that the hippocampus and the DMS mediate more flexible behavior, while the DLS supports S-R habit learning. However, there are some inconsistencies between these hypotheses and some findings reported in the literature. Although it was not tested whether rats overtrained in the cued version of the water maze are insensitive to reward devaluation, this task have been taken as a model of S-R learning (White, 2004; Packard, 2009; White, 2009). It is also generally accepted that the spatial version of this task is a good model of the spatial/relational learning, the kind of learning supported by the hippocampus and DMS, as stressed above. Then, it is expected that the lesion of the DLS, but not of the DMS, would impair learning of the cued version. However, the study by Devan et al. (1999) did not confirm this prediction: they found out that the lesion of the rat DMS impaired learning of both versions while the lesion of the DLS did not impair any of them. The assumption that the DLS is not involved in spatial navigation is also in disagreement with the finding that some neurons in the striatum respond to the animal location and head direction (Wiener, 1993; Mizumori et al., 2009). It is important to mention that these neurons are not restricted to the DMS, but were found in all regions of the striatum, including the DLS (Mizumori's personal communication).

1  
2  
3  
4  
5  
6  
7  
8  
9  
10  
11  
12  
13  
14  
15  
16  
17  
18  
19  
20  
21  
22  
23  
24  
25  
26  
27  
28  
29  
30  
31  
32  
33  
34  
35  
36  
37  
38  
39  
40  
41  
42  
43  
44  
45  
46  
47  
48  
49  
50  
51  
52  
53  
54  
55  
56  
57  
58  
59  
60

Such inconsistencies had lead to alternative theories about the interactions between the hippocampus and striatum in learning and performance of spatial navigation. Mizumori and co-workers (2009) hypothesized that, in addition to the hippocampus, all regions of the striatum contribute to spatial navigation. They proposed that, instead of competing for control over behavior, while the hippocampus extracts a spatial/relational map of the environment from sensory inputs, the striatum selects the proper actions to navigate according to the directions that can be taken from this map and that leads to a reward. According to them, the striatum performs this selection by applying the same computational pattern to the different inputs arriving to different parts of the striatum. Da Cunha and co-workers (2009) recently proposed a model called “the mosaic of broken mirrors” to explain the computational contribution of the striatum on learning and memory. In short, this model proposes that objects and locations are represented in functional units of the striatum, as well as the subject’s body (and body parts). The association of these units encodes the action of the subject (or the subject’s body part) towards a particular location or object of the environment. The indirect striatal inputs from the hippocampus make it a likely candidate to feed the striatum with information of near locations in relation to the subject. However, instead of encoding these locations based on the spatial relations among them (like the hippocampus does), according to the mosaic of broken mirrors model, they are encoded as fragments of the environment that are individually related to specific actions, but that cannot reconstitute the environment based on multiple relations among the environmental pieces.

Thus, instead of parallel memory systems that sometimes compete for the control over behavior, the hippocampus and the striatum may be systems with complementary roles in spatial navigation. If this is true, the lesion of the striatum plus the hippocampus would result in a deeper impairment in learning of both the spatial and cued versions of the Morris water maze. Such prediction is more particularly in confront with the prediction of the competition theory, if the striatum lesion were restricted to the DLS, which lesion is known to not affect the learning of both versions of this task (Devan et al., 1999). Testing this prediction is the aim of the present study.

## MATERIALS AND METHODS

### Subjects

Adult male Wistar rats from our own breeding stock weighing 280-320 g at the beginning of the experiments were used. The animals were housed individually in a temperature-controlled room ( $22 \pm 2^\circ\text{C}$ ) on a 12/12-h dark/light cycle (lights on at 7:00 a.m.) with food and water available *ad libitum*. All experimental procedures were in compliance with the guidelines laid down by the National Institute of Health and the Brazilian Society for Neuroscience and Behavior guidelines and were approved by the Institutional Animal Care and Use Committee of the Federal University of Paraná State.

### Surgery

Fourteen days before the beginning of the behavioral experiments, the animals received atropine sulfate (0.4 mg/kg, i.p.) to suppress salivation, penicillin G-procaine (20,000 U in 0.1 ml, i.m.) to prevent infection, and were anesthetized with 3 ml/kg i.p. equithesin (1% sodium thiopental, 4.25% chloral hydrate, 2.31% magnesium sulfate, 42.8% propylene glycol, and 3.7% ethanol in water). The animals were randomly assigned to one of four lesion groups, hereafter referred to as the dorsal hippocampus- (HIP), dorsolateral striatum- (DLS), dorsal hippocampus plus dorsolateral striatum- (HIP+DLS), and SHAM-lesioned groups (SHAM). The rats were placed in a stereotaxic frame (Kopf Instruments, Tujunga, CA) with the nose bar at - 3.3 mm from the interaural line and bilateral lesions in the HIP and/or DLS were performed by passing an anodic current of 2 mA for 15 s (HIP) and 6 mA for 20 s (DLS) through an stainless steel electrode insulated except for 0.7 mm from the tip. The following coordinates were used: HIP, anteroposterior (AP), -2.5, -3.5, -4.5 and -5.2 mm from the bregma; mediolateral (ML),  $\pm 1.5$ ,  $\pm 2.0$ ,  $\pm 2.5$  and  $\pm 4.0$  mm from the midline; dorsoventral (DV), -3.5, -4.0, -4.0 and -4.0 mm from the skull, respectively; DLS, AP = 0.0 and +1.0 mm, ML =  $\pm 4.0$  and  $\pm 3.5$  mm from the midline, DV = -5.5 and -5.5 mm, respectively. The SHAM group underwent the same procedures, with the electrode lowered to a position just to the target areas, but no current passed through the electrode.

## Behavioral procedures

The experiments were conducted between 1:00 and 6:00 p.m. The Morris water maze sessions were conducted in a round tank, 170 cm in diameter and 40 cm deep, filled with water. The water temperature was maintained at 22°C. Several distal visual cues were placed on the walls of the water maze room. During the experiments, the tank was videotaped and the traveled distance and latency to reach the escape platform, the swimming speed, and the swimming paths were recorded by an image analyzer (HVS System, Buckingham, UK).

**The spatial version** of the water maze task consisted of training the animals for various consecutive days, 4 trials per day, during which each animal was left in the tank facing the wall and allowed to swim freely to a transparent acrylic escape platform (11 x 14 cm) placed at a fixed location in the center of one of the quadrants of the tank, 35 cm away from the edge of the pool. The platform location was kept constant throughout the training days. The platform was submerged 2 cm under the water surface and could not be seen by the rats. The initial position in which the animal was left in the tank was one of the 4 cardinal vertices of the pool quadrants and varied among trials in a pseudorandom manner. If the animal did not find the platform during a period of 60 s it was gently guided to it. Then, it was allowed to remain on the platform for 20 s and removed from the tank, and this procedure was repeated with all the other rats, each of them returning to the tank in the next initial starting position until the 4 trials of that training day were completed. Scores of traveled distances and latencies to find the platform for the individual trials were averaged by a block of four trials conducted on the same day.

**The cued version** of the water maze task was similar to the previous experimental procedure, except that the position of the escape platform was cued by a 7-cm diameter white ball attached to the top of the platform and protruding above the water. Furthermore, the location of the platform was changed in a pseudorandom manner in each trial and was never repeated.

## Test schedules



1  
2  
3 Experiment 1 was planned to test the prediction (based on the  
4 hypothesis that spatial learning depends on both the hippocampus and DLS)  
5 that the HIP+DLS rats would present worse scores than HIP rats to learn the  
6 spatial version of the Morris water maze.  
7  
8  
9

10 Experiment 2 aimed to test the converse prediction, based on the  
11 hypothesis that cued learning also depends on both the hippocampus and DLS:  
12 it tested whether the HIP+DLS rats present worse scores than HIP or DSL rats  
13 to learn the cued version of the water maze.  
14  
15  
16

17 Experiment 3 was an extension of Experiment 1, and was aimed to test  
18 the prediction that pretraining the HIP rats in the cued version would reverse  
19 their deficit to learn the spatial version and that the HIP+DLS rats would not  
20 have the same benefit. This prediction was also based on the hypothesis that  
21 spatial learning depends on both the hippocampus and DSL.  
22  
23  
24  
25

26 Experiment 4 was an extension of Experiment 2, and was intended to  
27 test the prediction that pretraining the STR, but not the HIP+DLS, rats in the  
28 spatial version would reverse their deficit to learn the spatial version. This  
29 prediction was based on the hypothesis that cued learning depends on both the  
30 hippocampus and DSL.  
31  
32  
33  
34

35 In experiments 1 and 3, 10 SHAM, 10 HIP, 6 DLS, and 5 HIP+DLS rats  
36 were given 5 days of training in the spatial version of the water maze, and then  
37 2 more training days in the cued version. In experiments 2 and 4 other 10  
38 SHAM, 7 HIP, 6 DLS, and 6 HIP+DLS rats were given 5 days of training in the  
39 cued version and then 2 days in the spatial version.  
40  
41  
42  
43  
44

## 45 46 **Histology**

47  
48  
49 At the end of the experimental procedures, all rats were killed with an  
50 overdose of pentobarbital and were perfused transcardially with saline (NaCl  
51 0.9%) followed by 4% paraformaldehyde in 0.1 M phosphate buffer, pH 7.4 ; the  
52 brains were immediately removed and placed in the same paraformaldehyde  
53 solution for 72 h before sectioning. The brains were then cut in the frontal plane  
54 in 30 µm thick sections with a vibrating blade microtome (Leica, VT1000 S,  
55 Bensheim, Germany). The sections were mounted on gelatin-coated slides and  
56 stained with thionin. Only the animals with lesions limited to the DLS and the  
57  
58  
59  
60

1  
2  
3 dorsal hippocampus were included in the present analysis. The lesions were  
4 plotted with the aid of a camera lucida from the thionin-stained sections, and  
5 transferred onto a series of standard rat brain drawings (Swanson, 1992).  
6  
7  
8  
9

## 10 **Statistics**

11  
12  
13  
14 Escape latencies and traveled distances for the individual trials were averaged  
15 by trial block and analyzed by two-way ANOVA with repeated measures (trial  
16 block), followed by the Newman-Keuls test. Differences were considered to be  
17 statistically significant when  $p \leq 0.05$ .  
18  
19  
20  
21  
22  
23

## 24 **RESULTS**

25  
26  
27  
28 Two weeks after surgery, when submitted to the behavioral tests, no  
29 gross sensorimotor deficit was observed in the lesioned animals. They swam  
30 normally and the mean swimming speed did not differ significantly among the  
31 groups (SHAM =  $20.3 \pm 0.9$  cm/s; HIP =  $20.3 \pm 1.0$  cm/s; DLS =  $21.2 \pm 1.3$  cm/s;  
32 HIP+DLS =  $21.8 \pm 2.9$  cm/s;  $F(3,25) = 0.22$ ,  $P = 0.88$  ANOVA). Therefore,  
33 similar results were obtained for latencies or traveled distances to find the  
34 platform. In order to avoid presenting unnecessary information, only latency  
35 scores are shown.  
36  
37  
38  
39  
40  
41  
42

43 Experiment 1 examined whether combined lesions of the dorsal  
44 hippocampus and DLS of the rats cause a higher impairment to learn the spatial  
45 version of the water maze than the lesion of just one of these structures. The  
46 results presented in Figs. 1A and 4 show that this is the case. A two-way  
47 ANOVA showed significant group ( $F(3,27) = 12.47$ ,  $P < 0.001$ ) and session  
48 effects ( $F(4,108) = 20.89$ ,  $P < 0.001$ ), and a significant interaction between  
49 these factors ( $F(12, 108) = 2.38$ ,  $P < 0.01$ ). The DLS rats learned the task as  
50 the controls. The HIP rats took longer to find the hidden platform compared to  
51 SHAM rats, but the HIP+DLS rats performed even worse (see Fig. 1A for  
52 statistics). They presented no sign of learning at all. Although after the 3rd day  
53 of training the HIP group no longer significantly differed from the SHAM group  
54 (Fig. 1A), only the SHAM rats could swim directly to the hidden platform on the  
55  
56  
57  
58  
59  
60

1  
2  
3 last training day (first column of the Fig. 4). The HIP rats typically swam a little  
4 longer to find the platform and the HIP+DLS rats presented a random swimming  
5 path, as if they were completely lost.  
6  
7

8  
9 Experiment 2 examined the converse situation - whether the lesion of  
10 the dorsal hippocampus, in addition to the lesion of the DLS, causes higher  
11 impairment in the learning of the cued version of the water maze. This  
12 prediction was also confirmed, as can be seen in Fig. 1B and Fig. 5. A two-way  
13 ANOVA showed a significant group ( $F(3,25) = 8.15, P < 0.001$ ) and session  
14 effects ( $F(4,100) = 62.64, P < 0.001$ ), and a significant interaction between  
15 these factors ( $F(12, 100) = 3.77, P < 0.001$ ). The HIP and DLS rats learned the  
16 task as effectively as the SHAM rats, and only the HIP+DLS rats were deeply  
17 impaired to learn this version. Along the 5 training days they barely decreased  
18 the latency to find the cued platform (see Fig. 1B for post hoc statistics). As  
19 shown in the first column of Fig. 5, SHAM, HIP, and DLS, but not the HIP+DLS,  
20 rats swam directly to the cued platform in the last trial of the 5th training day.  
21  
22  
23  
24  
25  
26  
27  
28  
29

30 Experiments 3 and 4 further tested the hypothesis that the  
31 hippocampus and the DLS play complementary roles in spatial and cued  
32 learning. Experiment 3 tested the prediction that pretraining the HIP, but not the  
33 HIP+DLS, rats in the cued version would reverse their deficit to learn the spatial  
34 version. The converse prediction was tested in Experiment 4: the prediction that  
35 pretraining the HIP+DLS rats in the spatial version would not reverse their  
36 deficit to learn the cued version. Both predictions were confirmed.  
37  
38  
39  
40  
41

42 As shown in Figs. 2B and 5, pretraining the HIP rats in the cued version  
43 reversed their deficit to learn the spatial version, but the HIP+DLS rats did not  
44 get such benefit. A two-way ANOVA showed a significant group ( $F(3,25) = 4.37,$   
45  $P < 0.05$ ) and session ( $F(1,25) = 6.77, P < 0.05$ ) effects. No significant  
46 interaction between these factors was found ( $F(3, 25) = 1.26, P = 0.30$ ). Data of  
47 the first 2 trial blocks of the naive rats trained in the spatial version are repeated  
48 in Fig. 2A just for comparison purpose. Post hoc statistics can be seen in Fig.  
49 2B. Both the naive DLS rats and the DLS rats pretrained in the spatial version  
50 were not impaired to learn the spatial version. The pretraining of the HIP+DLS  
51 rats in the cued version did not reverse their deficit to learn the spatial version.  
52  
53  
54  
55  
56  
57  
58  
59

60 Conversely, HIP+DLS, but not DLS, rats were impaired to learn the  
cued version - even those pretrained in the spatial version (see Figs. 3 and 4).

1  
2  
3 A two-way ANOVA showed significant group ( $F(3,27) = 6.06, P < 0.001$ ) and  
4 session effects ( $F(1,27) = 20.38, P < 0.001$ ). No significant interaction between  
5 these factors was found ( $F(3, 27) = 0.02, P = 0.88$ ). Further statistic details can  
6 be seen in Fig. 3B. It is interesting to note that, as shown in Fig. 4, in their first  
7 trial in the cued version, SHAM and DLS rats typically searched for the platform  
8 in the place that it was during the previous pretraining sessions in the spatial  
9 version. This behavior was not observed in HIP rats. Later on, the SHAM, HIP,  
10 and DLS rats learned to swim more directly to the cued platform (Fig. 4). On the  
11 other hand, the HIP+DLS rats presented a random (and many times  
12 thigmotactic) swimming in their first trial in the cued version. Even in the last trial  
13 in the cued version, they kept presenting a disoriented swimming pattern, many  
14 times spending more time swimming near the starting location (Fig. 4).

15  
16 The patterns of hippocampal and striatal lesions are presented in Fig. 6  
17 and Fig. 7, respectively. The lesions of the hippocampus affected the dorsal  
18 CA1 and dentate gyrus. For the striatal lesions, we excluded those centered in  
19 the DMS, and kept the remaining lesions mostly restricted to the DLS. The  
20 nucleus accumbens was always spared in the striatum-lesioned rats.

## 21 22 23 24 25 26 27 28 29 30 31 32 33 34 35 36 37 **DISCUSSION**

38  
39  
40 We replicated the results of previous studies showing that the learning  
41 impairment of HIP rats was selective to the spatial version of the water maze  
42 (Morris et al., 1982; Packard and McGaugh, 1992; Lee et al., 2008); while rats  
43 bearing lesions in the dorsal striatum (sparing most parts of the DMS)  
44 presented no impairment in both versions of the water maze (Whishaw et al.,  
45 1987; McDonald and White, 1994). Our results are also in agreement with a  
46 study by Devan et al. (1999) that showed that the lesion of the DMS, but not of  
47 the DLS impaired rats to learn the cued version of the water maze (but see  
48 Furtado and Mazurek, 1996). These findings have been taken as evidence of  
49 the “multiple memory systems” theory that proposes that the hippocampus and  
50 the dorsal striatum are, respectively, core structures in the memory systems  
51 specialized in spatial/relational and in cued-based (S-R) learning and memory  
52 (White and McDonald, 2002; Squire, 2004).  
53  
54  
55  
56  
57  
58  
59  
60

1  
2  
3  
4  
5  
6  
7  
8  
9  
10  
11  
12  
13  
14  
15  
16  
17  
18  
19  
20  
21  
22  
23  
24  
25  
26  
27  
28  
29  
30  
31  
32  
33  
34  
35  
36  
37  
38  
39  
40  
41  
42  
43  
44  
45  
46  
47  
48  
49  
50  
51  
52  
53  
54  
55  
56  
57  
58  
59  
60

However, such view is inconsistent with the present findings that combined lesions of DLS and dorsal hippocampus caused a learning impairment in both the spatial and cue-guided versions of the water maze that was dramatic compared to the impairment caused by the lesion of just one of them (see Fig. 1). Neither do our findings support the view of the hippocampus and the striatum as two systems competing for the control over navigation behavior (McDonald and White, 1993; Poldrack et al., 2001; Poldrack and Packard, 2003; Avila et al., 2009). On the contrary, our finding confirms our predictions based on the hypothesis that both the hippocampus and striatum are critical for spatial and cue-based navigation, as has been proposed more recently (Mizumori et al., 2009).

This hypothesis is also supported by our finding that pretraining HIP rats in the cued version reversed their impairment to learn the spatial version (see Fig. 2), a result similar to that reported in a study with DMS rats by Devan et al. (1999). Conversely, we found that the pretraining of DLS rats in the spatial version has improved their learning of the cued version (see Fig. 3). We have also reported similar results in a previous study with substantia nigra *pars compacta* (SNc)-lesioned rats (Da Cunha et al., 2007). However, the HIP+DLS rats had no benefit from the pretraining treatment on either conditions (Figs. 2 and 3). These results suggest that a kind of latent learning mediated by the DLS occurred during the pretraining sessions of the HIP rats in the cued version and that it helped them to solve the spatial version. Conversely, it seems that a latent learning mediated by the dorsal hippocampus occurred during the pretraining sessions in the spatial task, helped the DLS rats to solve the cued version.

Cooperative interactions between the hippocampus and the dorsal striatum during learning of other tasks have also been reported in previous studies (Hikosaka and Wurtz, 1983; Hikosaka et al., 1989; Gardiner and Kitai, 1992; Devan and White, 1999; Mizumori et al., 2000; Ragozzino et al., 2001; White and McDonald, 2002; Tariot et al., 2004; Voermans et al., 2004; Yeshenko et al., 2004; Gengler et al., 2005; Hartley et al., 2005; Eschenko and Mizumori, 2007; Bonsi et al., 2008; Puryear and Mizumori, 2008; Tort et al., 2008). In addition, both the hippocampus and striatum are active while humans perform spatial and cued-based navigation tasks (Henke et al., 2003; Degonda

1  
2  
3 et al., 2005; Schendan and Stern, 2008). However, there are also reports of  
4 competitive interactions between the hippocampus and the dorsal striatum  
5 during learning of some other tasks (McDonald and White, 1993; Poldrack et  
6 al., 2001; Poldrack and Packard, 2003; Mizumori et al., 2004; Avila et al., 2009).  
7  
8  
9

10 The main role of the hippocampus in navigation is to process sensory  
11 information in order to map the subject's environment (Wilson and McNaughton,  
12 1993). However, no action is associated to this map. Therefore, the  
13 hippocampus cannot provide an action solution while navigating to search for a  
14 reward. It only provides the information necessary for another system to choose  
15 the proper action to achieve such goal. The striatum, on the other hand, fulfills  
16 the attributes to play this action-selection role (Frank and Claus, 2006). While  
17 the hippocampal place cells do not encode actions and reward, the striatal cells  
18 encode place-action and cue-action associations (Schmitzer-Torbert and  
19 Redish, 2008). Striatal neurons also fire in response to specific locations,  
20 egocentric movements, directional heading, and reward expectation (Wiener,  
21 1993; Lavoie and Mizumori, 1994; Mizumori et al., 2000; Schultz, 2006;  
22 Eschenko and Mizumori, 2007; Lau and Glimcher, 2007; Puryear and Mizumori,  
23 2008; Schmitzer-Torbert and Redish, 2008; Mizumori et al., 2009).  
24  
25  
26  
27  
28  
29  
30  
31  
32  
33  
34

35 Many studies also showed striatal neurons reorganization when the  
36 spatial context is changed. However, a recent study by Berke et al. (2009)  
37 reported not having found such place-related cells in the striatum of rats  
38 performing a cued version of a plus maze task. In this task, thirsty animals keep  
39 entering the arm signaled by a visual cue in order to get drops of sweet water.  
40 This strategy, called win-stay, is considered to depend on the dorsal striatum,  
41 but not on the dorsal hippocampus (Packard et al., 1989; McDonald and White,  
42 1993). At Berke's et al. study (2009), they recorded simultaneously from the  
43 dorsal hippocampus and from different regions of the dorsal and ventral  
44 striatum. They found more than 70% of the projection neurons recorded in the  
45 CA1 region of the dorsal hippocampus firing unambiguously when the rat was in  
46 a specific place in the maze (place cells), but they found no striatal neuron with  
47 this firing pattern. Some striatal neurons fired when the animals were in the  
48 center of the maze, when they arrived to the end of the baited arm, and when  
49 they were at the same distance from the end of a baited arm. These results  
50  
51  
52  
53  
54  
55  
56  
57  
58  
59  
60

1  
2  
3 were taken as evidence against the theory that the striatum can encode spatial  
4 locations, at least at that task.  
5

6  
7 Another recent study by Schmitzer-Torbert and Redish (2008) also  
8 reported that they did not find neurons in the striatum that fired when a rat was  
9 in a particular location during performance of the take-5 task. This task cannot  
10 be solved with the use of a spatial strategy. However, by using ensembles of  
11 striatal neurons, they could reconstitute the position of the rat in the maze when  
12 it was performing a spatial task called multiple-T. Therefore, differently from the  
13 place cells of the hippocampus, some striatal neurons seem to encode spatial  
14 parameters only when performing a task in which the goal can be  
15 unambiguously associated to a location. These neurons can also respond to the  
16 stage of the task and to rewards, properties not found in the hippocampal place  
17 cells. These findings may explain why Berke et al. (2009) did not find striatal  
18 place-related cells, since they recorded from animals that were performing a  
19 task that could not be unambiguously solved by using a spatial strategy.  
20  
21 However, this hypothesis cannot explain why, in the present study, the lesion of  
22 the DLS plus the dorsal hippocampus caused impairment in the learning of the  
23 cued version of the water maze that was dramatic, compared to impairment  
24 caused by the lesion of the hippocampus, since this task can be solved with a  
25 non-spatial strategy.  
26  
27

28  
29 The “mosaic of broken mirrors model” can accommodate these  
30 apparently contradictory findings. It proposes that the striatum does not encode  
31 the space as a continuum. Instead, it breaks the environment into fragments,  
32 i.e., objects or locations that the animal should approach to be rewarded (Da  
33 Cunha et al., 2009). This may explain why Berke and his colleagues (2009)  
34 found striatal neurons that fired when the rat was at the same distance from the  
35 end of the maze, no matter in which arm it was. Remember that, in this task, the  
36 reward is placed just in the end of the cued arm and the striatal neurons are  
37 expected to fire to encode the distance between the animal and a cue that  
38 signals the reward location. The “mosaic of broken mirrors model” can also  
39 explain why the striatum cannot distinguish ambiguous locations without using a  
40 visual cue as a landmark (White and McDonald, 2002). According to this model,  
41 the striatal neurons are expected to fire as if they encoded the animal’s location  
42 only in situations with different cues marking the place of a reward, a condition  
43  
44  
45  
46  
47  
48  
49  
50  
51  
52  
53  
54  
55  
56  
57  
58  
59  
60

1  
2  
3 not available in the take-5 task (Schmitzer-Torbert and Redish, 2008). The  
4  
5 worse navigation of the HIP+DLS rats in relation to the DLS rats when they  
6  
7 performed the cued version of the water maze suggests that the striatum picks  
8  
9 up the fragmented locations of the environment from the hippocampal cognitive  
10  
11 map. This provides a relevant role for the projection neurons of the dorsal  
12  
13 hippocampus to sustain the encoding of the location of the reward by the striatal  
14  
15 neurons, even when the animal is performing a non-spatial task, as observed by  
16  
17 Berke et al. (2009). The encoding of the space in unrelated pieces (sometimes  
18  
19 cued by objects of the environment) also makes sense considering the  
20  
21 dimensionality reduction that occurs in cortical to striatal encoding of  
22  
23 sensorymotor information (Bar-Gad et al., 2003; Da Cunha et al., 2009).  
24  
25 According to the “mosaic of broken mirrors model”, during this process, the  
26  
27 cognitive map of the space, based on multiple relations among the objects of  
28  
29 the environment, is reduced into places cued only by a particular object or into  
30  
31 places that are at the same distance from a relevant cue.

32  
33 According to this view, the results of the present study can be  
34  
35 compared to the situation of two guys looking for an address in Rio de Janeiro.  
36  
37 One of them, Hippocampus, has the map but cannot drive. The other, Striatum,  
38  
39 is a driver without the map. Hippocampus says to Striatum – turn right on  
40  
41 Copacabana Ave., go straight ahead for three blocks, turn left at Rodolfo  
42  
43 Dantas St., turn left again at Barata Ribeiro St., and stop at Cardeal Arco Verde  
44  
45 Square. Striatum looks for the names of the roads and uses egocentric  
46  
47 orientation to make the correct turns. Trial after trial, Striatum learns to relate  
48  
49 the corners to other sights – turn right at the Coffee place, turn left at the mall,  
50  
51 and so on. After habituation, he no longer needs the Hippocampus’ map to find  
52  
53 the address. He drives randomly if he cannot count on Hippocampus. He takes  
54  
55 much longer, but can eventually find the address by chance and, trial after trial,  
56  
57 he learns to find it by using cues in an egocentric strategy. However, he gets  
58  
59 lost when departing from the opposite side of the city. Hippocampus, on his  
60  
61 way, is in trouble to find the address without the driver. He can ask someone  
62  
63 else to drive him there, but this person is not used to his instructions and takes  
64  
65 longer to find the address. However, the more dramatic situation is when both  
66  
67 Striatum and Hippocampus are missing – then, the car is empty.



1  
2  
3 In conclusion, instead of parallel memory systems competing for the  
4 control over navigational behavior, the hippocampus should be seen as the  
5 system that encodes the environmental/contextual space and the striatum as  
6 another system that selects the action that heads navigation towards the reward  
7 location, both systems with memory properties.  
8  
9  
10  
11  
12  
13  
14  
15

16 **Acknowledgements:** We thank Jamile Moreira Cugler, Silvia Cordazzo Genari,  
17 and Lindacir R. Nascimento for technical assistance.  
18  
19  
20  
21  
22  
23  
24  
25  
26  
27  
28  
29  
30  
31  
32  
33  
34  
35  
36  
37  
38  
39  
40  
41  
42  
43  
44  
45  
46  
47  
48  
49  
50  
51  
52  
53  
54  
55  
56  
57  
58  
59  
60

For Peer Review

## REFERENCES

- 1  
2  
3  
4  
5  
6  
7  
8  
9  
10  
11  
12  
13  
14  
15  
16  
17  
18  
19  
20  
21  
22  
23  
24  
25  
26  
27  
28  
29  
30  
31  
32  
33  
34  
35  
36  
37  
38  
39  
40  
41  
42  
43  
44  
45  
46  
47  
48  
49  
50  
51  
52  
53  
54  
55  
56  
57  
58  
59  
60
- Avila I, Reilly MP, Sanabria F, Posadas-Sanchez D, Chavez CL, Banerjee N, Killeen P and Castaneda E (2009) Modeling operant behavior in the Parkinsonian rat. *Behavioural Brain Research* 198:298-305.
- Balleine BW, Liljeholm M and Ostlund SB (2009) The integrative function of the basal ganglia in instrumental conditioning. 199:43-52.
- Bar-Gad I, Morris G and Bergman H (2003) Information processing, dimensionality reduction and reinforcement learning in the basal ganglia. *Progress in Neurobiology* 71:439-473.
- Berke JD, Breck JT and Eichenbaum H (2009) Striatal Versus Hippocampal Representations During Win-Stay Maze Performance. *Journal of Neurophysiology* 101:1575-1587.
- Bird CM and Burgess N (2008) The hippocampus and memory: Insights from spatial processing. *Nature Reviews Neuroscience* 9:182-194.
- Bonsi P, Platania P, Martella G, Madeo G, Vita D, Tassone A, Bernardi G and Pisani A (2008) Distinct roles of group I mGlu receptors in striatal function. *Neuropharmacology* 55:392-395.
- Byrne P, Becker S and Burgess N (2007) Remembering the past and imagining the future: a neural model of spatial memory and imagery. *Psychol. Reviews* 114:340-375.
- Cenquizca LA and Swanson LW (2007) Spatial organization of direct hippocampal field CA1 axonal projections to the rest of the cerebral cortex. *Brain Research Reviews* 56:1-26.
- Chavarriaga R, Strosslin T, Sheynikhovich D and Gerstner W (2005) Competition between cue response and place response: a model of rat navigation behaviour. *Connection Science* 17:167-183.
- Da Cunha C, Wietzikoski EC, Dombrowski P, Santos LM, Bortolanza M, Boschen SL and Miyoshi E (2009) Learning processing in the basal ganglia: A mosaic of broken mirrors. *Behavioural Brain Research* 199:156-169.
- Da Cunha C, Wietzikoski S, Wietzikoski EC, Silva MHC, Chandler J, Ferro MM, Andreatini R and Canteras NS (2007) Pre-training to find a hidden

1  
2  
3 platform in the Morris water maze can compensate for a deficit to find a  
4  
5 cued platform in a rat model of Parkinson's disease. *Neurobiology of*  
6  
7 *Learning and Memory* 87:451-463.

8  
9 Degonda N, Mondadori CR, Bosshardt S, Schmidt CF, Boesiger P, Nitsch RM,  
10  
11 Hock C and Henke K (2005) Implicit associative learning engages the  
12  
13 hippocampus and interacts with explicit associative learning. *Neuron*  
14  
15 46:505-520.

16  
17 Devan BD, McDonald RJ and White NM (1999) Effects of medial and lateral  
18  
19 caudate-putamen lesions on place- and cue-guided behaviors in the  
20  
21 water maze: relation to thigmotaxis. *Behavioural Brain Research* 100:5-  
22  
23 14.

24  
25 Devan BD and White NM (1999) Parallel information processing in the dorsal  
26  
27 striatum: relation to hippocampal function. *J Neurosci* 19:2789-2798.

28  
29 Eichenbaum H (2002) *The Cognitive Neuroscience of Memory: An Introduction*.  
30  
31 NY: Oxford University Press. Oxford University Press, NY.

32  
33 Eschenko O and Mizumori SJY (2007) Memory influences on hippocampal and  
34  
35 striatal neural codes: Effects of a shift between task rules. *Neurobiology*  
36  
37 *of Learning and Memory* 87:495-509.

38  
39 Frank MJ and Claus ED (2006) Anatomy of a decision: Striato-orbitofrontal  
40  
41 interactions in reinforcement learning, decision making, and reversal.  
42  
43 *Psychological Review* 113:300-326.

44  
45 Furtado JCS and Mazurek MF (1996) Behavioral characterization of  
46  
47 quinolinate-induced lesions of the medial striatum: relevance for  
48  
49 Huntington's disease. *Experimental Neurology* 138:158-168.

50  
51 Gardiner TW and Kitai ST (1992) Single-unit activity in the globus pallidus and  
52  
53 neostriatum of the rat during performance of a trained head movement.  
54  
55 *Exp Brain Res* 88:517-530.

56  
57 Gengler S, Mallot HA and Holscher C (2005) Inactivation of the rat dorsal  
58  
59 striatum impairs performance in spatial tasks and alters hippocampal  
60  
theta in the freely moving rat. *Behavioural Brain Research* 164:73-82.

Hafting T, Fyhn M, Molden S, Moser MB and Moser EI (2005) Microstructure of  
a spatial map in the entorhinal cortex. *Nature* 436:801-806.

- 1  
2  
3  
4  
5  
6  
7  
8  
9  
10  
11  
12  
13  
14  
15  
16  
17  
18  
19  
20  
21  
22  
23  
24  
25  
26  
27  
28  
29  
30  
31  
32  
33  
34  
35  
36  
37  
38  
39  
40  
41  
42  
43  
44  
45  
46  
47  
48  
49  
50  
51  
52  
53  
54  
55  
56  
57  
58  
59  
60
- Hartley M, Taylor N and Taylor J (2005) Subfield variations in hippocampal processing - components of a spatial navigation system. *Neural Networks* 18:611-619.
- Henke K, Treyer V, Nagy ET, Kneifel S, Dursteler M, Nitsch RM and Buck A (2003) Active hippocampus during nonconscious memories. *Conscious Cogn* 12:31-48.
- Hikosaka O, Sakamoto M and Usui S (1989) Functional properties of monkey caudate neurons. III. Activities related to expectation of target and reward. *J Neurophysiol* 61:814-832.
- Hikosaka O and Wurtz RH (1983) Visual and oculomotor functions of monkey substantia nigra pars reticulata. III. Memory-contingent visual and saccade responses. *J Neurophysiol* 49:1268-1284.
- Lau B and Glimcher PW (2007) Action and outcome encoding in the primate caudate nucleus. *Journal of Neuroscience* 27:14502-14514.
- Lavoie AM and Mizumori SJY (1994) Spatial, Movement-Sensitive and Reward-Sensitive Discharge by Medial Ventral Striatum Neurons of Rats. *Brain Research* 638:157-168.
- Lee AS, Duman RS and Pittenger C (2008) A double dissociation revealing bidirectional competition between striatum and hippocampus during learning. *Proceedings of the National Academy of Sciences of the United States of America* 105:17163-17168.
- McDonald RJ and White NM (1993) A triple dissociation of memory systems: hippocampus, amygdala, and dorsal striatum. *Behav Neurosci* 107:3-22.
- McDonald RJ and White NM (1994) Parallel Information-Processing in the Water Maze - Evidence for Independent Memory-Systems Involving Dorsal Striatum and Hippocampus. *Behavioral and Neural Biology* 61:260-270.
- McGeorge AJ and Faull RLM (1989) The Organization of the Projection from the Cerebral-Cortex to the Striatum in the Rat. *Neuroscience* 29:503-537.
- Mizumori SJ, Cooper BG, Leutgeb S and Pratt WE (2000) A neural systems analysis of adaptive navigation. *Mol Neurobiol* 21:57-82.
- Mizumori SJ, Yeshenko O, Gill KM and Davis DM (2004) Parallel processing across neural systems: implications for a multiple memory system hypothesis. *Neurobiol Learn Mem* 82:278-298.

- 1  
2  
3 Mizumori SJY, Puryear CB and Martig AK (2009) Basal ganglia contributions to  
4 adaptive navigation. *Behavioural Brain Research* 199:32-42.  
5  
6  
7 Morris RG, Garrud P, Rawlins JN and O'Keefe J (1982) Place navigation  
8 impaired in rats with hippocampal lesions. *Nature* 297:681-683.  
9  
10 Nadel L and O'Keefe J (1978) *The hippocampus as a cognitive map*. Oxford  
11 University Press, Oxford, England.  
12  
13  
14 O'Keefe J and Nadel L (1978) *The Hippocampus as a Cognitive Map*. Clarendon  
15 Press, Oxford.  
16  
17  
18 Packard MG (2009) Exhumed from thought: Basal ganglia and response  
19 learning in the plus-maze. *Behavioural Brain Research* 199:24-31.  
20  
21 Packard MG, Hirsh R and White NM (1989) Differential-Effects of Fornix and  
22 Caudate-Nucleus Lesions on 2 Radial Maze Tasks - Evidence for  
23 Multiple Memory-Systems. *Journal of Neuroscience* 9:1465-1472.  
24  
25  
26 Packard MG and McGaugh JL (1992) Double dissociation of fornix and caudate  
27 nucleus lesions on acquisition of two water maze tasks: further evidence  
28 for multiple memory systems. *Behav Neurosci* 106:439-446.  
29  
30  
31 Poldrack RA, Clark J, Pare-Blagoev EJ, Shohamy D, Creso Moyano J, Myers C  
32 and Gluck MA (2001) Interactive memory systems in the human brain.  
33 *Nature* 414:546-550.  
34  
35  
36  
37 Poldrack RA and Packard MG (2003) Competition among multiple memory  
38 systems: converging evidence from animal and human brain studies.  
39 *Neuropsychologia* 41:245-251.  
40  
41  
42 Potegal M, Copack P, Jong J, Krautham.G and Gilman S (1971) Vestibular  
43 Input to Caudate Nucleus. *Experimental Neurology* 32:448-&.  
44  
45  
46 Puryear CB and Mizumori SJY (2008) Reward prediction error signals by  
47 reticular formation neurons. *Learning & Memory* 15:895-898.  
48  
49  
50 Ragozzino KE, Leutgeb S and Mizumori SJY (2001) Dorsal striatal head  
51 direction and hippocampal place representations during spatial  
52 navigation. *Experimental Brain Research* 139:372-376.  
53  
54  
55 Ramanathan S, Hanley JJ, Deniau JM and Bolam JP (2002) Synaptic  
56 convergence of motor and somatosensory cortical afferents onto  
57 GABAergic interneurons in the rat striatum  
58  
59  
60 *Journal of Neuroscience* 22:8158-5859.

- 1  
2  
3 Schendan HE and Stern CE (2008) Where vision meets memory: Prefrontal-  
4 posterior networks for visual object constancy during categorization and  
5 recognition. *Cerebral Cortex* 18:1695-1711.  
6  
7  
8  
9 Schmitzer-Torbert NC and Redish AD (2008) Task-dependent encoding of  
10 space and events by striatal neurons is dependent on neural subtype.  
11 *Neuroscience* 153:349-360.  
12  
13  
14 Schultz W (2006) Behavioral theories and the neurophysiology of reward.  
15 *Annual Review of Psychology* 57:87-115.  
16  
17  
18 Squire LR (2004) Memory systems of the brain: A brief history and current  
19 perspective. *Neurobiology of Learning and Memory* 82:171-177.  
20  
21 Squire LR, Stark CE and Clark RE (2004) The medialtemporal lobe. *Annual*  
22 *Review of Neuroscience* 27:279-306.  
23  
24  
25 Swanson LW (1992) *Brain Maps: structure of the rat brain*. Elsevier,  
26 Amsterdam.  
27  
28 Tariot PN, Farlow MR, Grossberg GT, Graham SM, McDonald S and Gergel I  
29 (2004) Memantine treatment in patients with moderate to severe  
30 Alzheimer disease already receiving donepezil - A randomized controlled  
31 trial. *Jama-Journal of the American Medical Association* 291:317-324.  
32  
33  
34 Tolman EC (1948) Cognitive maps in rats and men. *Psychological Review*  
35 56:144-155.  
36  
37  
38 Tort ABL, Kramer MA, Thorn C, Gibson DJ, Kubota Y, Graybiel AM and Kopell  
39 NJ (2008) Dynamic cross-frequency couplings of local field potential  
40 oscillations in rat striatum and hippocampus during performance of a T-  
41 maze task. *Proceedings of the National Academy of Sciences of the*  
42 *United States of America* 105:20517-20522.  
43  
44  
45  
46  
47 Veening JG, Cornelissen FM and Lieven JM (1980) The topical organization of  
48 the afferents to the caudatoputamen of the rat. A horseradish peroxidase  
49 study. *Neuroscience* 5:1253-1268.  
50  
51  
52  
53 Voermans NC, Petersson KM, Daudey L, Weber B, Van Spaendonck KP,  
54 Kremer HP and Fernandez G (2004) Interaction between the human  
55 hippocampus and the caudate nucleus during route recognition. *Neuron*  
56 43:427-435.  
57  
58  
59  
60

- 1  
2  
3 Voorn P, Vanderschuren L, Groenewegen HJ, Robbins TW and Pennartz CMA  
4 (2004) Putting a spin on the dorsal-ventral divide of the striatum. *Trends*  
5 *in Neurosciences* 27:468-474.  
6  
7  
8  
9 Whishaw IQ, Mittleman G, Bunch ST and Dunnett SB (1987) Impairments in the  
10 Acquisition, Retention and Selection of Spatial Navigation Strategies  
11 after Medial Caudate-Putamen Lesions in Rats. *Behavioural Brain*  
12 *Research* 24:125-138.  
13  
14  
15 White NM (2004) The role of stimulus ambiguity and movement in spatial  
16 navigation: A multiple memory systems analysis of location  
17 discrimination. *Neurobiology of Learning and Memory* 82:216-229.  
18  
19  
20 White NM (2009) Some highlights of research on the effects of caudate nucleus  
21 lesions over the past 200 years. *Behavioural Brain Research* 199:3-23.  
22  
23  
24 White NM and McDonald RJ (2002) Multiple parallel memory systems in the  
25 brain of the rat. *Neurobiol Learn Mem* 77:125-184.  
26  
27  
28 Wiener SI (1993) Spatial and behavioral correlates of striatal neurons in rats  
29 performing a self-initiated navigation task. *Journal of Neuroscience*  
30 13:3802-3817.  
31  
32  
33 Wilson MA and McNaughton BL (1993) Dynamics of the Hippocampal  
34 Ensemble Code for Space. *Science* 261:1055-1058.  
35  
36  
37 Yeshenko O, Guazzelli A and Mizumori SJ (2004) Context-dependent  
38 reorganization of spatial and movement representations by  
39 simultaneously recorded hippocampal and striatal neurons during  
40 performance of allocentric and egocentric tasks. *Behav Neurosci*  
41 118:751-769.  
42  
43  
44 Yin HH and Knowlton BJ (2006) The role of the basal ganglia in habit formation.  
45 *Nature Reviews Neuroscience* 7:464-476.  
46  
47  
48 Yin HH, Knowlton BJ and Balleine BW (2004) Lesions of dorsolateral striatum  
49 preserve outcome expectancy but disrupt habit formation in instrumental  
50 learning. *European Journal of Neuroscience* 19:181-189.  
51  
52  
53 Yin HH, Knowlton BJ and Balleine BW (2005) Blockade of NMDA receptors in  
54 the dorsomedial striatum prevents action-outcome learning in  
55 instrumental conditioning. *European Journal of Neuroscience* 22:505-  
56 512.  
57  
58  
59  
60

1  
2  
3 Yin HH, Knowlton BJ and Balleine BW (2006) Inactivation of dorsolateral  
4 striatum enhances sensitivity to changes in the action-outcome  
5 contingency in instrumental conditioning. *Behavioural Brain Research*  
6  
7 166:189-196.  
8  
9  
10  
11  
12  
13  
14  
15  
16  
17  
18  
19  
20  
21  
22  
23  
24  
25  
26  
27  
28  
29  
30  
31  
32  
33  
34  
35  
36  
37  
38  
39  
40  
41  
42  
43  
44  
45  
46  
47  
48  
49  
50  
51  
52  
53  
54  
55  
56  
57  
58  
59  
60

For Peer Review



## FIGURE LEGENDS

**Fig. 1.** Effects of the bilateral lesion of the dorsal hippocampus (HIP) and/or dorsolateral striatum (DLS) on learning the spatial (A) and cued (B) versions of the water maze. Data are expressed as mean  $\pm$  SEM. \*  $P < 0.05$  compared to the SHAM group; #  $P < 0.05$  compared to HIP group; Newman Keuls after two-way ANOVA.

**Fig. 2.** Effect of pretraining in the cued version rats with bilateral lesions in the dorsal hippocampus (HIP) and/or dorsolateral striatum (DLS) on learning the **spatial version** of the water maze. The pretraining consisted of 4 trials in the cued version for 5 days. Data are expressed as mean  $\pm$  SEM to find the platform before (A) and after (B) the pretraining sessions. \*  $P < 0.05$  compared to the SHAM group; #  $P < 0.05$  compared to the HIP group; Newman Keuls after two-way ANOVA.

**Fig. 3.** Effect of pretraining in the spatial version rats with bilateral lesions in the dorsal hippocampus (HIP) and/or dorsolateral striatum (DLS) on learning the **cued version** of the water maze. The pretraining consisted of 4 trials in the spatial version for 5 days. Data are expressed as mean  $\pm$  SEM to find the platform before (A) and after (B) the pretraining sessions. \*  $P < 0.05$  compared to the SHAM group; #  $P < 0.05$  compared to the DLS group; Newman Keuls after two-way ANOVA.

**Fig. 4.** Individual swim paths of rats bearing bilateral lesions in the dorsal hippocampus (HIP) and/or dorsolateral striatum (DLS), that were trained in the spatial version of the water maze for 5 days and then in the cued version for 2 further days. The paths shown are representative of the last trial of the 5th training day in the spatial version of the water maze, of the first trail in the cued version, and of the last trial in the cued version. The black circle indicates the location of the cued platform, the black square the location of the hidden platform, and the dotted square the location in which the hidden platform was in the previous trial.

1  
2  
3  
4  
5 **Fig. 5.** Individual swim paths of rats bearing bilateral lesions in the dorsal  
6 hippocampus (HIP) and/or dorsolateral striatum (DLS), that were trained in the  
7 cued version of the water maze for 5 days and then in the spatial version for 2  
8 further days. The paths shown are representative of the last trial of the 5th  
9 training day in the spatial version of the water maze, of the first trail in the cued  
10 version, and of the last trial in the cued version. The black circle indicates the  
11 location of the cued platform and the black square the location of the hidden  
12 platform.  
13  
14  
15  
16  
17  
18  
19

20  
21 **Fig. 6.** Reconstruction of coronal sections through the hippocampus showing  
22 the smallest (dark gray) and the largest (gray) lesion centered in the dorsal CA1  
23 and dentate gyrus. In the upper right corner of each figure, the approximate  
24 distance (mm) from the bregma is indicated.  
25  
26  
27  
28

29  
30 **Fig. 7.** Reconstruction of coronal sections through the striatum showing the  
31 smallest (dark gray) and the largest (gray) lesion centered in the DLS. In the  
32 upper right corner of each figure, the approximate distance (mm) from the  
33 bregma is indicated.  
34  
35  
36  
37  
38  
39  
40  
41  
42  
43  
44  
45  
46  
47  
48  
49  
50  
51  
52  
53  
54  
55  
56  
57  
58  
59  
60

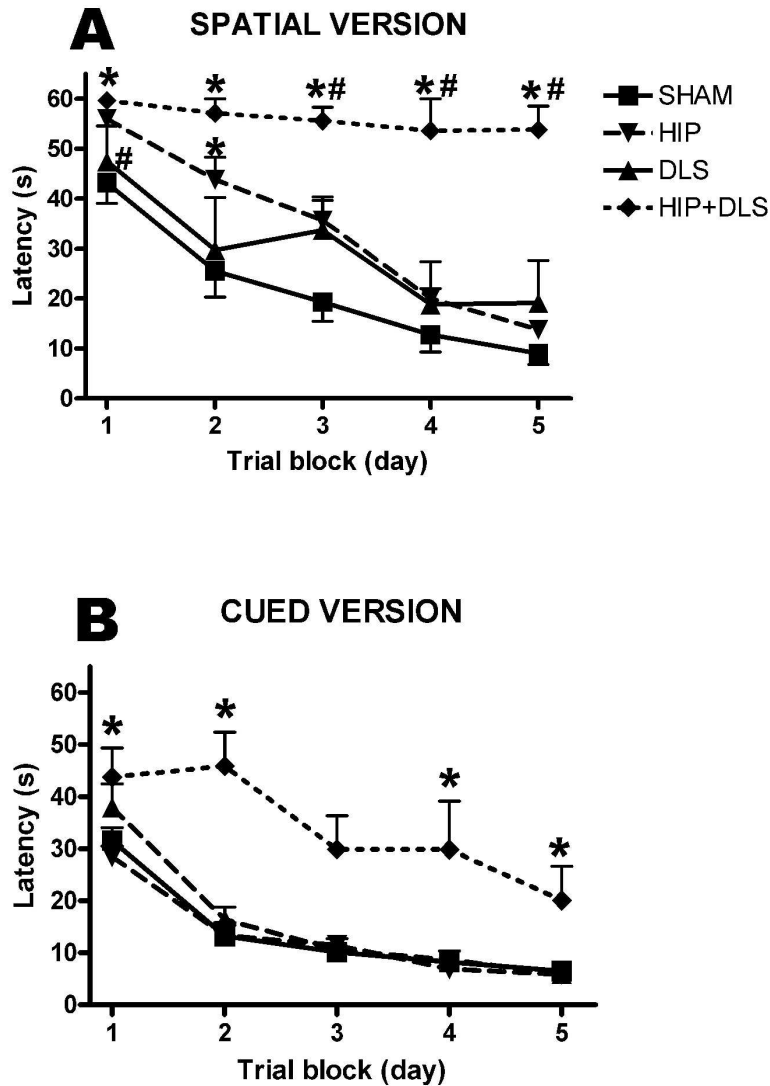

Fig. 1. Effects of the bilateral lesion of the dorsal hippocampus (HIP) and/or dorsolateral striatum (DLS) on learning the spatial (A) and cued (B) versions of the water maze. Data are expressed as mean  $\pm$  SEM. \*  $P < 0.05$  compared to the SHAM group; #  $P < 0.05$  compared to HIP group; Newman Keuls after two-way ANOVA.  
125x174mm (600 x 600 DPI)

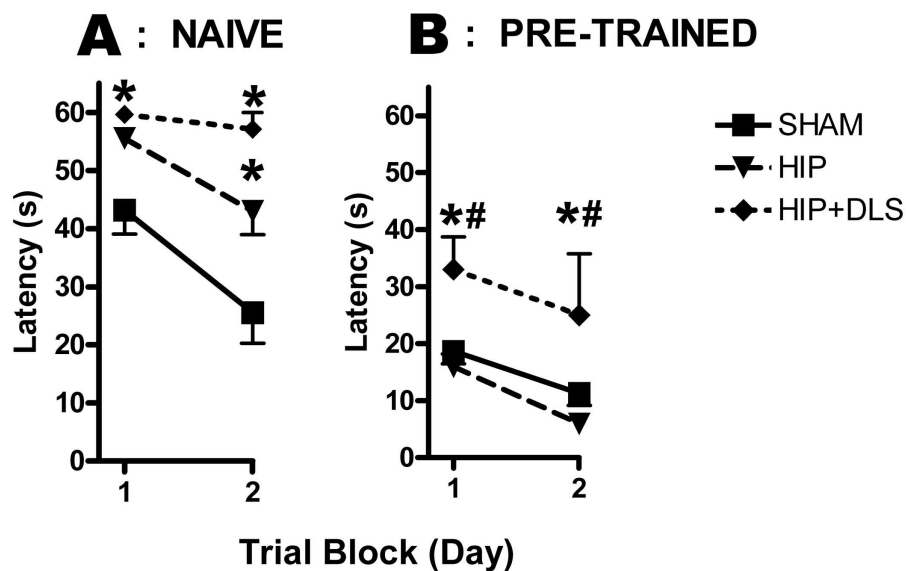

Fig. 2. Effect of pretraining in the cued version rats with bilateral lesions in the dorsal hippocampus (HIP) and/or dorsolateral striatum (DLS) on learning the spatial version of the water maze. The pretraining consisted of 4 trials in the cued version for 5 days. Data are expressed as mean  $\pm$  SEM to find the platform before (A) and after (B) the pretraining sessions. \*  $P < 0.05$  compared to the SHAM group; #  $P < 0.05$  compared to the HIP group; Newman Keuls after two-way ANOVA. 99x65mm (600 x 600 DPI)

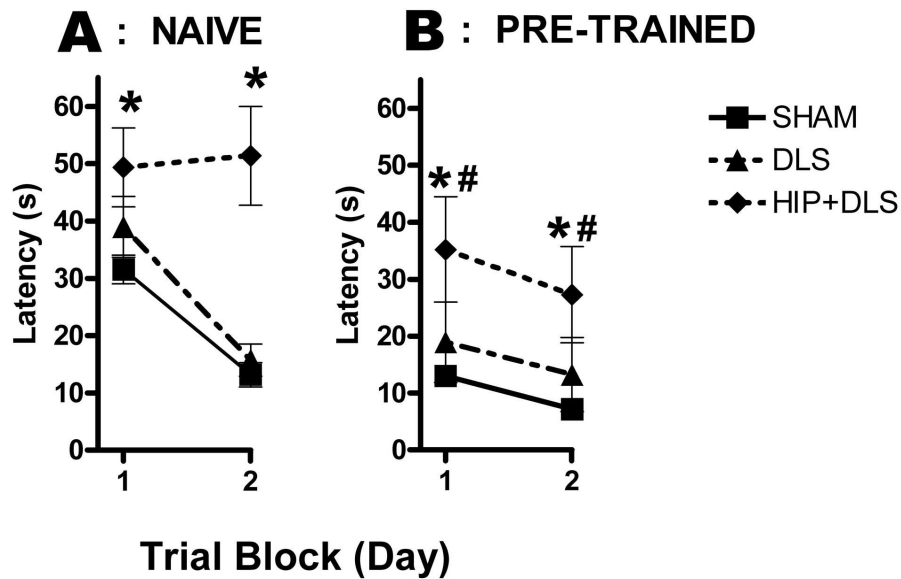

Fig. 3. Effect of pretraining in the spatial version rats with bilateral lesions in the dorsal hippocampus (HIP) and/or dorsolateral striatum (DLS) on learning the cued version of the water maze. The pretraining consisted of 4 trials in the spatial version for 5 days. Data are expressed as mean  $\pm$  SEM to find the platform before (A) and after (B) the pretraining sessions. \*  $P < 0.05$  compared to the SHAM group; #  $P < 0.05$  compared to the DLS group; Newman Keuls after two-way ANOVA.

90x61mm (600 x 600 DPI)

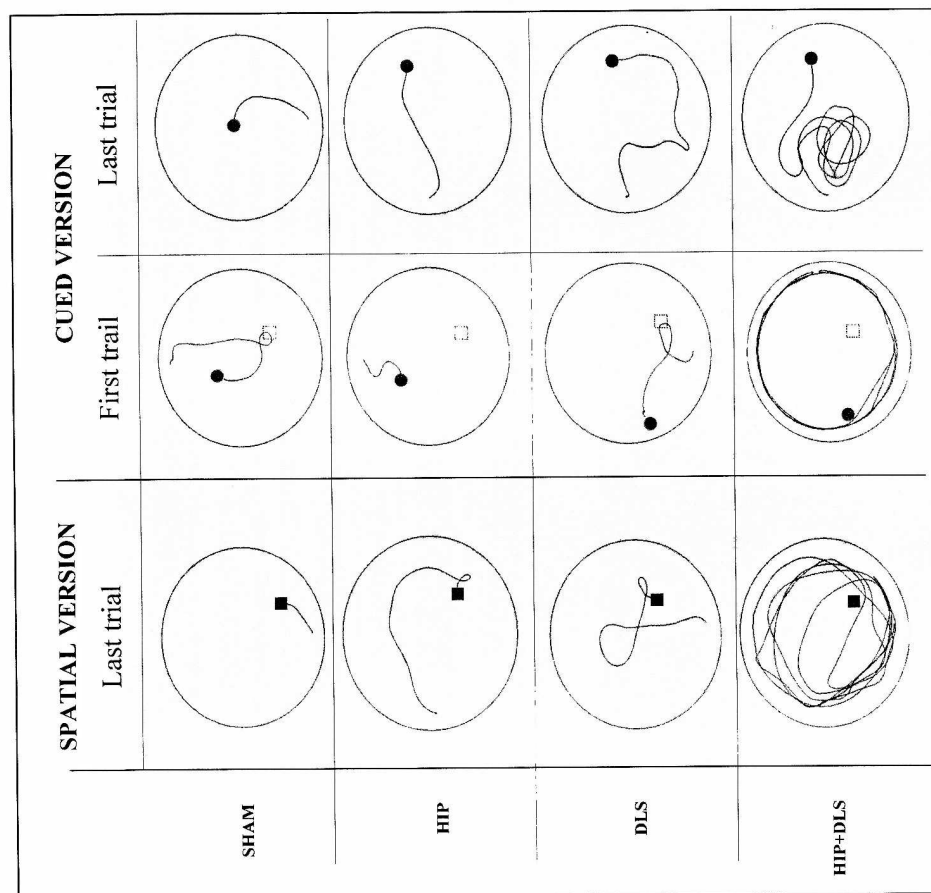

Fig. 4. Individual swim paths of rats bearing bilateral lesions in the dorsal hippocampus (HIP) and/or dorsolateral striatum (DLS), that were trained in the spatial version of the water maze for 5 days and then in the cued version for 2 further days. The paths shown are representative of the last trial of the 5th training day in the spatial version of the water maze, of the first trail in the cued version, and of the last trial in the cued version. The black circle indicates the location of the cued platform, the black square the location of the hidden platform, and the dotted square the location in which the hidden platform was in the previous trial.

200x194mm (600 x 600 DPI)

1  
2  
3  
4  
5  
6  
7  
8  
9  
10  
11  
12  
13  
14  
15  
16  
17  
18  
19  
20  
21  
22  
23  
24  
25  
26  
27  
28  
29  
30  
31  
32  
33  
34  
35  
36  
37  
38  
39  
40  
41  
42  
43  
44  
45  
46  
47  
48  
49  
50  
51  
52  
53  
54  
55  
56  
57  
58  
59  
60

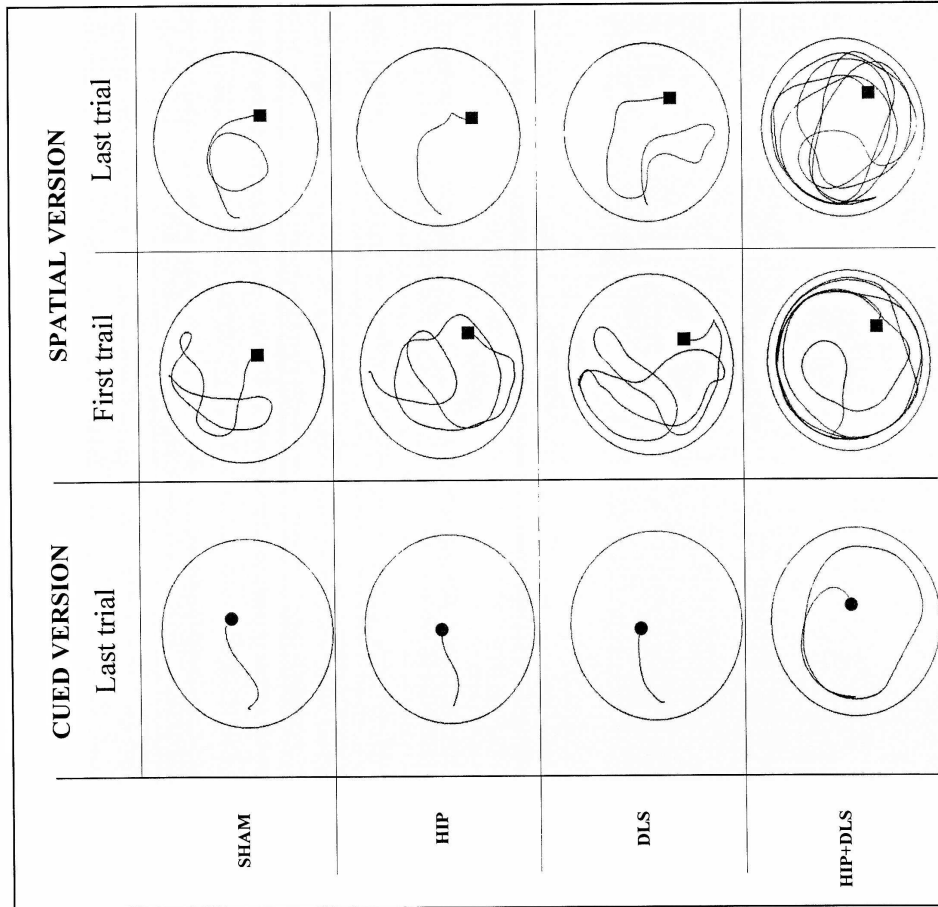

Fig. 5. Individual swim paths of rats bearing bilateral lesions in the dorsal hippocampus (HIP) and/or dorsolateral striatum (DLS), that were trained in the cued version of the water maze for 5 days and then in the spatial version for 2 further days. The paths shown are representative of the last trial of the 5th training day in the spatial version of the water maze, of the first trail in the cued version, and of the last trial in the cued version. The black circle indicates the location of the cued platform and the black square the location of the hidden platform.  
196x190mm (600 x 600 DPI)

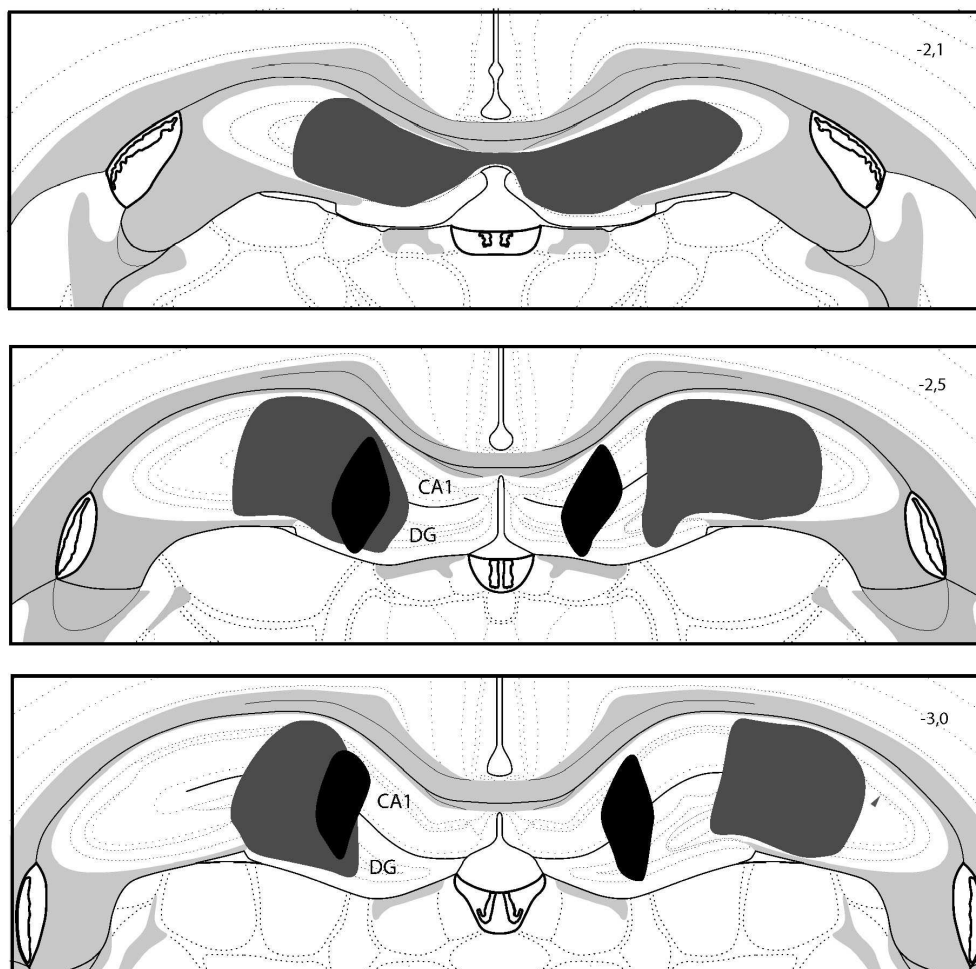

Fig. 6. Reconstruction of coronal sections through the hippocampus showing the smallest (dark gray) and the largest (gray) lesion centered in the dorsal CA1 and dentate gyrus. In the upper right corner of each figure, the approximate distance (mm) from the bregma is indicated.  
117x116mm (400 x 400 DPI)



1  
2  
3  
4  
5  
6  
7  
8  
9  
10  
11  
12  
13  
14  
15  
16  
17  
18  
19  
20  
21  
22  
23  
24  
25  
26  
27  
28  
29  
30  
31  
32  
33  
34  
35  
36  
37  
38  
39  
40  
41  
42  
43  
44  
45  
46  
47  
48  
49  
50  
51  
52  
53  
54  
55  
56  
57  
58  
59  
60

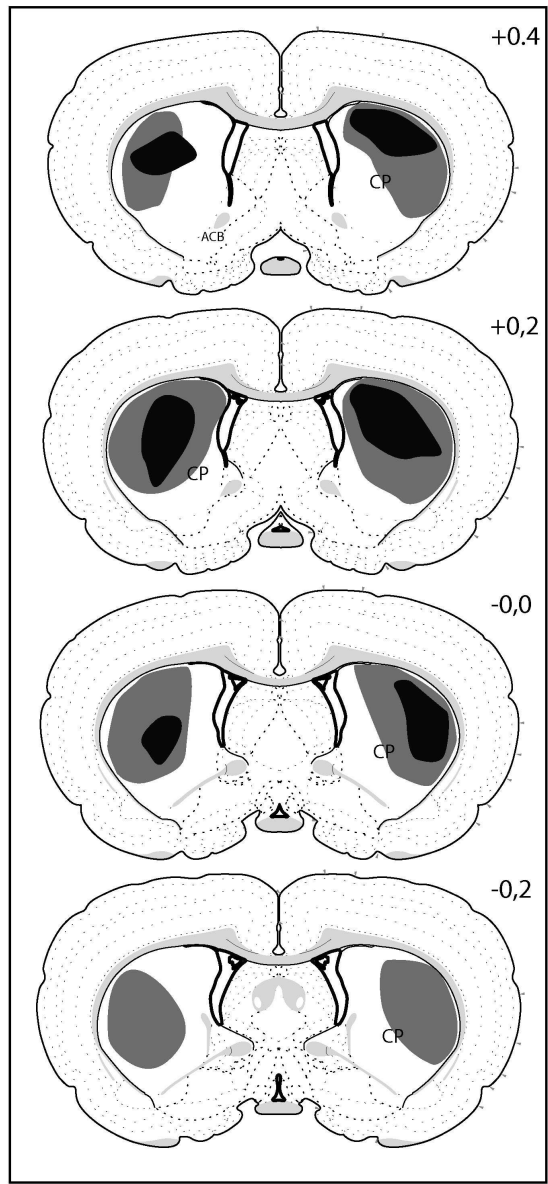

Fig. 7. Reconstruction of coronal sections through the striatum showing the smallest (dark gray) and the largest (gray) lesion centered in the DLS. In the upper right corner of each figure, the approximate distance (mm) from the bregma is indicated.  
88x189mm (400 x 400 DPI)

#### 4 DISCUSSÃO

Uma teoria bastante aceita na literatura é a dupla dissociação entre o sistema hipocampal e o sistema estriatal nos processos de aprendizado e memória, onde o hipocampo é importante para a memória declarativa, enquanto que o estriado é importante para a memória de procedimento (Packard e Mcgaugh, 1992; Mcdonald e White, 1994; Packard e Knowlton, 2002; White e Mcdonald, 2002; Packard, 2009; White, 2009). Os nossos resultados reforçam a teoria de que o hipocampo dorsal é importante para a navegação espacial no labirinto aquático de Morris, já que os animais com lesão apenas do hipocampo dorsal apresentaram um prejuízo no desempenho desta versão do labirinto (Morris, Garrud *et al.*, 1982; Packard e Mcgaugh, 1992). Além disso, mostramos também que quando lesionamos bilateralmente apenas o hipocampo dorsal não alteramos o desempenho dos animais na versão com pista visual (Packard e Mcgaugh, 1992). Isto sugere que o hipocampo dorsal é importante apenas para o aprendizado relacional (S-S) e não tem influência no aprendizado S-R-O.

Entretanto, como os animais com lesão apenas do DLS não apresentaram prejuízo em ambas as versões do labirinto aquático, estes resultados contradizem a teoria de Packard e Mcgaugh (1992), a qual sugere que o estriado dorsal prejudica apenas a versão com pista visual (Packard e Mcgaugh, 1992). Entretanto, no trabalho realizado por Packard e Mcgaugh (1992) foram lesionados os estriados dorsais, sem delimitar estas lesões no DMS ou DLS. As lesões foram tanto no DMS quanto no DLS.

Os nossos resultados estão de acordo com os trabalhos de DEVAN e colaboradores (Devan, Mcdonald *et al.*, 1999) que mostram uma dissociação entre o DMS e o DLS, onde a lesão do DLS não prejudica nenhuma versão (espacial e com pista visual) do labirinto aquático. Estes resultados diferentes encontrados com as lesões do DLS e do DMS levaram a

subdivisão funcional do estriado. Nesta nova visão, o DMS passou a ser considerado por estes autores com parte do sistema hipocampal de memória espacial ou S-S (White, 2009) enquanto o sistema estriatal, ou S-R-O, ficou restrito ao DLS (White, 2009). Porém, mesmo esta nova visão não consegue explicar todos os resultados disponíveis, pois os animais com lesão apenas do DLS não apresentaram prejuízo na versão com pista, sugerindo que o DLS não seria importante para o aprendizado S-R-O.

Resultados interessantes foram obtidos quando submetemos os animais a um pré-treinamento no labirinto aquático. Quando os animais com lesão do hipocampo dorsal são pré-treinados, na versão com pista visual do labirinto aquático, e então testados na versão espacial, eles apresentaram um desempenho semelhante aos animais do grupo SHAM. Isto sugere que alguma informação adquirida pelo DLS no pré-treinamento foi utilizada para auxiliar a navegação espacial no labirinto aquático.

Como sabemos que foi o DLS que participou na aquisição desta informação? É porque quando lesionamos o hipocampo dorsal e o DLS (grupo HIP+DLS), mesmo com o pré-treinamento os animais não conseguiram aprender a versão espacial do labirinto aquático. Então, isto sugere que o DLS interage com o sistema hipocampal na navegação em um labirinto aquático. Além disso, que esta interação é do tipo cooperativa (Mizumori, Cooper *et al.*, 2000; Voermans, Petersson *et al.*, 2004; Hartley e Burgess, 2005). Isto também sugere que não só o hipocampo dorsal, mas também o DLS tem um papel na navegação espacial no labirinto aquático (Mizumori, Puryear *et al.*, 2009).

Esta cooperação entre o hipocampo dorsal e o DLS também foi observada quando os animais foram pré-treinados na versão espacial e depois testados na versão com pista visual. Os animais SHAM, HIP e DLS apresentaram um desempenho semelhante na versão com pista visual. Mas, os animais com lesão dupla (grupo HIP+DLS) apresentaram um desempenho pior que estes três grupos. Ou seja, quando a lesão ocorre só no hipocampo ou só

no DLS, os animais desempenham normalmente a tarefa, mas quando a lesão ocorre em ambas as estruturas estes animais apresentam um prejuízo. Isto sugere este papel cooperativo entre o hipocampo dorsal e o DLS na navegação no labirinto aquático (Mizumori, Puryear *et al.*, 2009).

Como vários trabalhos mostram que o hipocampo dorsal tem a capacidade de codificar o ambiente formando um mapa cognitivo através da atividade de neurônios denominados de células de lugar ou *place cells* (Wilson e McNaughton, 1993). Uma explicação alternativa é que o papel do hipocampo dorsal na navegação no labirinto aquático é processar as informações sensoriais para mapear o ambiente através dos diversos estímulos (objetos) presentes fora do labirinto aquático. Porém, o hipocampo não tem a capacidade de coordenar as respostas motoras (ações) e nem detectar as recompensas obtidas durante a realização desta navegação. Quem desempenharia esta seleção de quais as ações deveriam ser tomadas para se conseguir uma recompensa seria o estriado ou ao menos uma parte dele, i.e., DLS. Isto porque o estriado dorsal apresenta neurônios que se ativam quando o animal executa movimentos com orientação egocêntrica, direcionamento da cabeça para locais específicos e também em função da expectativa de recompensa (Lavoie e Mizumori, 1994; Mizumori, Cooper *et al.*, 2000; Schultz, 2006; Schmitzer-Torbert e Redish, 2008; Mizumori, Puryear *et al.*, 2009).

Este papel do DLS na seleção de ações durante a navegação no labirinto aquático pode ser explicado pelo modelo do mosaico dos espelhos quebrados (anexo 2) (Da Cunha, Wietzikoski *et al.*, 2009). Segundo este modelo, o córtex sensorial e motor enviam projeções para o estriado de forma convergente e repetitiva. Em função destas projeções estímulos sensoriais (partes do corpo, objetos e partes do ambiente) são representados de forma fragmentada e repetida no estriado. Cada fragmento forma uma unidade funcional no estriado. Quando uma unidade funcional do estriado é ativada ao mesmo tempo por projeções do

sensorial (representando uma parte do corpo e um objeto), por projeções do córtex motor (representando a ação da parte do corpo sobre objeto) e por projeções de neurônios dopaminérgicos mesencefálicos (ativados de forma fásica pela novidade) ocorrem fenômenos de plasticidade sináptica que podem fortalecer ou enfraquecer estas associações. Este fortalecimento desta associação na via direta (estriado – Gpi/SNr) e o enfraquecimento da via indireta (estriado – Gpe – NST – Gpi/SNr) faz com que a aquela ação recompensada que foi deflagrada por aquele estímulo seja reforçada.

Portanto, nossos resultados sugerem que a interação entre o hipocampo dorsal e o DLS não é de forma cooperativa ou competitiva, mas complementar, ou seja, que estas duas estruturas desempenhem funções diferentes, mas indispensáveis para a navegação espacial e também na navegação orientada por pistas. Nesta complementariedade, o hipocampo mapearia o ambiente enquanto que o estriado selecionaria quais são as ações a serem tomadas durante a navegação.

## 5 CONCLUSÕES

Os resultados desta tese questionam de forma crítica a teoria de que o hipocampo dorsal seja suficiente para controlar o comportamento de navegação espacial baseado em memórias relacionais (S-S), tal como na versão espacial do labirinto aquático de Morris. Assim como, de que o DLS seja suficiente para mediar a navegação baseada em pistas (aprendizagem S-R-O), tal como na versão com pista visual do labirinto aquático de Morris. Ou seja, esta tese apresenta evidências de que tanto o hipocampo dorsal quanto o DLS sejam necessários para mediar a aquisição de comportamentos de navegação baseados tanto em memórias S-S como S-R-O.

## REFERÊNCIAS BIBLIOGRÁFICAS

- Albouy, G., V. Sterpenich, *et al.* Both the hippocampus and striatum are involved in consolidation of motor sequence memory. Neuron, v.58, n.2, Apr 24, p.261-72. 2008.
- Balleine, B. W., M. Liljeholm, *et al.* The integrative function of the basal ganglia in instrumental conditioning. Behav Brain Res, v.199, n.1, Apr 12, p.43-52. 2009.
- Berke, J. D., J. T. Breck, *et al.* Striatal versus hippocampal representations during win-stay maze performance. J Neurophysiol, v.101, n.3, Mar, p.1575-87. 2009.
- Da Cunha, C., M. E. Angelucci, *et al.* The lesion of the rat substantia nigra pars compacta dopaminergic neurons as a model for Parkinson's disease memory disabilities. Cell Mol Neurobiol, v.22, n.3, Jun, p.227-37. 2002.
- Da Cunha, C., M. S. Gevaerd, *et al.* Memory disruption in rats with nigral lesions induced by MPTP: a model for early Parkinson's disease amnesia. Behav Brain Res, v.124, n.1, Sep 28, p.9-18. 2001.
- Da Cunha, C., M. H. Silva, *et al.* Place learning strategy of substantia nigra pars compacta-lesioned rats. Behav Neurosci, v.120, n.6, Dec, p.1279-84. 2006.
- Da Cunha, C., E. C. Wietzikoski, *et al.* Learning processing in the basal ganglia: a mosaic of broken mirrors. Behav Brain Res, v.199, n.1, Apr 12, p.157-70. 2009.
- Da Cunha, C., S. Wietzikoski, *et al.* Evidence for the substantia nigra pars compacta as an essential component of a memory system independent of the hippocampal memory system. Neurobiol Learn Mem, v.79, n.3, May, p.236-42. 2003.
- \_\_\_\_\_. Pre-training to find a hidden platform in the Morris water maze can compensate for a deficit to find a cued platform in a rat model of Parkinson's disease. Neurobiol Learn Mem, v.87, n.4, May, p.451-63. 2007.
- Devan, B. D., R. J. McDonald, *et al.* Effects of medial and lateral caudate-putamen lesions on place- and cue-guided behaviors in the water maze: relation to thigmotaxis. Behav Brain Res, v.100, n.1-2, Apr, p.5-14. 1999.
- Doeller, C. F., J. A. King, *et al.* Parallel striatal and hippocampal systems for landmarks and boundaries in spatial memory. Proc Natl Acad Sci U S A, v.105, n.15, Apr 15, p.5915-20. 2008.
- Eichenbaum, H. Hippocampus: cognitive processes and neural representations that underlie declarative memory. Neuron, v.44, n.1, Sep 30, p.109-20. 2004.
- Eichenbaum, H., C. Stewart, *et al.* Hippocampal representation in place learning. J Neurosci, v.10, n.11, Nov, p.3531-42. 1990.
- Gold, J. J. e L. R. Squire. The anatomy of amnesia: neurohistological analysis of three new cases. Learn Mem, v.13, n.6, Nov-Dec, p.699-710. 2006.
- Goodrich-Hunsaker, N. J., S. A. Livingstone, *et al.* Spatial deficits in a virtual water maze in amnesic participants with hippocampal damage. Hippocampus, Jun 24. 2009.
- Guillazo-Blanch, G., R. Nadal, *et al.* Effects of fimbria lesions on trace two-way active

- avoidance acquisition and retention in rats. Neurobiol Learn Mem, v.78, n.2, Sep, p.406-25. 2002.
- Hartley, T. e N. Burgess. Complementary memory systems: competition, cooperation and compensation. Trends Neurosci, v.28, n.4, Apr, p.169-70. 2005.
- Hull, C. L. Principles of behavior. New York: Appleton. 1943
- Izquierdo, I. Memória. Porto Alegre: Artmed Editora. 2002. 95 p.
- Knowlton, B. J., J. A. Mangels, *et al.* A neostriatal habit learning system in humans. Science, v.273, n.5280, Sep 6, p.1399-402. 1996.
- Lavoie, A. M. e S. J. Mizumori. Spatial, movement- and reward-sensitive discharge by medial ventral striatum neurons of rats. Brain Res, v.638, n.1-2, Feb 28, p.157-68. 1994.
- Lee, A. S., R. S. Duman, *et al.* A double dissociation revealing bidirectional competition between striatum and hippocampus during learning. Proc Natl Acad Sci U S A, v.105, n.44, Nov 4, p.17163-8. 2008.
- Mcdonald, R. J., N. S. Hong, *et al.* The challenges of understanding mammalian cognition and memory-based behaviours: an interactive learning and memory systems approach. Neurosci Biobehav Rev, v.28, n.7, Nov, p.719-45. 2004.
- Mcdonald, R. J. e N. M. White. Parallel information processing in the water maze: evidence for independent memory systems involving dorsal striatum and hippocampus. Behav Neural Biol, v.61, n.3, May, p.260-70. 1994.
- Miyoshi, E., S. Wietzikoski, *et al.* Impaired learning in a spatial working memory version and in a cued version of the water maze in rats with MPTP-induced mesencephalic dopaminergic lesions. Brain Res Bull, v.58, n.1, May, p.41-7. 2002.
- Mizumori, S. J., B. G. Cooper, *et al.* A neural systems analysis of adaptive navigation. Mol Neurobiol, v.21, n.1-2, Feb-Apr, p.57-82. 2000.
- Mizumori, S. J. Y., C. B. Puryear, *et al.* Basal ganglia contributions to adaptive navigation. Behavioural Brain Research, v.199, n.1, Apr 12, p.32-42. 2009.
- Morris, R. G., P. Garrud, *et al.* Place navigation impaired in rats with hippocampal lesions. Nature, v.297, n.5868, Jun 24, p.681-3. 1982.
- Oliveira, M. G., O. F. Bueno, *et al.* Strategies used by hippocampal- and caudate-putamen-lesioned rats in a learning task. Neurobiol Learn Mem, v.68, n.1, Jul, p.32-41. 1997.
- Packard, M. G. Exhumed from thought: Basal ganglia and response learning in the plus-maze. Behavioural Brain Research, v.199, n.1, Apr 12, p.24-31. 2009.
- Packard, M. G., R. Hirsh, *et al.* Differential effects of fornix and caudate nucleus lesions on two radial maze tasks: evidence for multiple memory systems. J Neurosci, v.9, n.5, May, p.1465-72. 1989.
- Packard, M. G. e B. J. Knowlton. Learning and memory functions of the Basal Ganglia. Annu Rev Neurosci, v.25, p.563-93. 2002.



Packard, M. G. e J. L. Mcgaugh. Double dissociation of fornix and caudate nucleus lesions on acquisition of two water maze tasks: further evidence for multiple memory systems. Behav Neurosci, v.106, n.3, Jun, p.439-46. 1992.

Packard, M. G. e L. A. Teather. Double dissociation of hippocampal and dorsal-striatal memory systems by posttraining intracerebral injections of 2-amino-5-phosphonopentanoic acid. Behav Neurosci, v.111, n.3, Jun, p.543-51. 1997.

\_\_\_\_\_. Amygdala modulation of multiple memory systems: hippocampus and caudate-putamen. Neurobiol Learn Mem, v.69, n.2, Mar, p.163-203. 1998.

Packard, M. G. e N. M. White. Lesions of the caudate nucleus selectively impair "reference memory" acquisition in the radial maze. Behav Neural Biol, v.53, n.1, Jan, p.39-50. 1990.

Poldrack, R. A. e M. G. Packard. Competition among multiple memory systems: converging evidence from animal and human brain studies. Neuropsychologia, v.41, n.3, p.245-51. 2003.

Prediger, R. D., L. C. Batista, *et al.* The risk is in the air: Intranasal administration of MPTP to rats reproducing clinical features of Parkinson's disease. Exp Neurol, v.202, n.2, Dec, p.391-403. 2006.

Prediger, R. D., D. Rial, *et al.* Risk is in the air: an intranasal MPTP (1-methyl-4-phenyl-1,2,3,6-tetrahydropyridine) rat model of Parkinson's disease. Ann N Y Acad Sci, v.1170, Jul, p.629-36. 2009.

Salmon, D. P. e N. Butters. Neurobiology of skill and habit learning. Curr Opin Neurobiol, v.5, n.2, Apr, p.184-90. 1995.

Schmitzer-Torbert, N. C. e A. D. Redish. Task-dependent encoding of space and events by striatal neurons is dependent on neural subtype. Neuroscience, v.153, n.2, May 2, p.349-360. 2008.

Schultz, W. Behavioral theories and the neurophysiology of reward. Annual Review of Psychology, v.57, p.87-115. 2006.

Scoville, W. B. e B. Milner. Loss of recent memory after bilateral hippocampal lesions. J Neurol Neurosurg Psychiatry, v.20, n.1, Feb, p.11-21. 1957.

Squire, L. R. Memory systems of the brain: A brief history and current perspective. Neurobiology of Learning and Memory, v.82, n.3, Nov, p.171-177. 2004.

\_\_\_\_\_. The legacy of patient H.M. for neuroscience. Neuron, v.61, n.1, Jan 15, p.6-9. 2009.

Squire, L. R., C. E. Stark, *et al.* The medial temporal lobe. Annu Rev Neurosci, v.27, p.279-306. 2004.

Thorndike, E. L. Animal intelligence: experimental studies. New York: Macmillan. 1911

Torras-Garcia, M., D. Costa-Miserachs, *et al.* Improvement of shuttle-box performance by anterodorsal medial septal lesions in rats. Behav Brain Res, v.141, n.2, May 15, p.147-58. 2003.

Voermans, N. C., K. M. Petersson, *et al.* Interaction between the human hippocampus and the caudate nucleus during route recognition. Neuron, v.43, n.3, Aug 5, p.427-35. 2004.

White, N. M. Some highlights of research on the effects of caudate nucleus lesions over the past 200 years. Behavioural Brain Research, v.199, n.1, Apr 12, p.3-23. 2009.

White, N. M. e R. J. McDonald. Multiple parallel memory systems in the brain of the rat. Neurobiol Learn Mem, v.77, n.2, Mar, p.125-84. 2002.

Wilson, M. A. e B. L. McNaughton. Dynamics of the Hippocampal Ensemble Code for Space. Science, v.261, n.5124, Aug 20, p.1055-1058. 1993.

Xavier, G. F. e V. C. Costa. Dentate gyrus and spatial behaviour. Prog Neuropsychopharmacol Biol Psychiatry, v.33, n.5, Aug 1, p.762-73. 2009.

Yin, H. H. e B. J. Knowlton. The role of the basal ganglia in habit formation. Nat Rev Neurosci, v.7, n.6, Jun, p.464-76. 2006.

## ANEXOS

Além deste trabalho realizado durante a tese, foram publicados outros artigos. Apresento aqui, nos anexos, estes trabalhos que foram publicados. No primeiro trabalho revisamos os trabalhos que mostram o papel da substância negra nos processos de aprendizado e memória, exemplificando com o que acontece em pacientes com doença de Parkinson. No segundo trabalho, a partir de trabalhos já publicados, elaboramos e apresentamos uma nova teoria para explicar como os gânglios da base participam nos processos de aprendizado de memórias de procedimentos.

**ANEXO 1**

## **A RAT MODEL OF THE COGNITIVE IMPAIRMENTS IN PARKINSON'S DISEASE**

*UN MODELO EN RATA FRL DETERIORO COGNITIVO  
EN LA ENFERMEDAD DE PARKINSON*

**CLAUDIO DA CUNHA<sup>1\*</sup> RUI D. S. PREDIGER<sup>2</sup> EDMAR MIYOSHI<sup>1,3</sup>  
REINALDO N. TAKAHASHI<sup>2</sup>**

<sup>1</sup>LABORATÓRIO DE FISIOLOGIA E FARMACOLOGIA DO SISTEMA NERVOSO CENTRAL, DEPARTAMENTO DE FARMACOLOGIA, UFPR, C.P. 19.031, 81.531-980, CURITIBA-PR, BRAZIL.

<sup>2</sup>DEPARTAMENTO DE FARMACOLOGIA, CENTRO DE CIÊNCIAS BIOLÓGICAS, UNIVERSIDADE FEDERAL DE SANTA CATARINA, UFSC, FLORIANÓPOLIS-SC, BRAZIL.

<sup>3</sup>DEPARTAMENTO DE CIÊNCIAS FARMACÊUTICAS, UNIVERSIDADE ESTADUAL DE PONTA GROSSA, PONTA GROSSA-PR, BRAZIL.

### **ABSTRACT**

Although Parkinson's disease (PD) is classically considered to be a motor system disease, subtle cognitive impairments can be observed even during the early phases of PD. In this article we review behavioral and neurochemical studies on the cognitive alterations observed in rats treated with intranigral infusion of the neurotoxin MPTP. The critical role of dopamine release in the dorsal striatum and its modulation by adenosine receptors is also reviewed as a potential strategy to treat the cognitive disabilities of PD patients who do not improve with levodopa therapy. Most of the impairments presented by rats treated with intranigral infusion of MPTP are similar to those observed during the early phase of PD, when a moderate loss of nigral dopamine neurons (40-70%) results in sensory and memory deficits with no major motor impair-

---

\* This work was supported by CNPq, Fundação Araucária, Institutos de Milênio, and CAPES. Corresponding author: Laboratório de Fisiologia e Farmacologia do Sistema Nervoso Central, Departamento de Farmacologia, UFPR, C.P. 19.031, 81.531-980, Curitiba-PR, Brazil. Phone 55

ments. These animals also model the working memory and habit learning deficits, with long-term spatial (episodic) memories being mostly spared as observed in non-demented PD patients. The intranigral infusion of MPTP in rats has led to the development of useful models, which do not present gross motor impairments that would otherwise compromise the interpretation of the performance of the animals in cognitive tasks.

*Keywords: Parkinson's disease, learning, memory, cognition, MPTP, rats, animal model.*

## RESUMEN

Aunque el mal de Parkinson (DP) es considerado clásicamente como un desorden del sistema motor, pueden observarse ligeros deterioros cognitivos aun en las fases iniciales del DP. En este artículo revisamos estudios conductuales y neuroquímicos sobre alteraciones cognitivas observadas en ratas tratadas con infusiones intranigrales de la neurotoxina MPTP. El papel crítico de la liberación de dopamina en el estriado dorsal y su modulación por los receptores de adenosina también es revisada como una estrategia potencial para tratar los deterioros cognitivos en pacientes con desorden de Parkinson (PD) que no mejoran con la terapia de *levo dopa*. Resultados: La mayoría de los daños presentados en ratas con infusiones intranigrales de MPTP son similares a los observados en las primeras fases de PD, una pérdida moderada de neuronas nigrales dopaminérgicas (40-70%) que causa déficits sensoriales y motores y poco deterioro motor. Estos animales también modelan los déficits de memoria de trabajo y aprendizaje de hábitos, con la memoria de largo plazo espacial (episódica) mayormente preservada como se observa en los pacientes sin DP. La infusión intranigral de MPTP en ratas a llevado al desarrollo de modelos útiles, ya que no presentan un deterioro motor excesivo que podría de otra manera comprometer la interpretación de la ejecución de los animales en tareas cognitivas.

*Palabras clave: mal de Parkinson, aprendizaje, memoria, cognición, MPTP, ratas, modelo animal.*

Parkinson's disease (PD) is the second most common neurodegenerative disorder, following Alzheimer's disease, affecting approximately 1% of the population older than 50 years (Duvoisin 1991). Current estimates from the American Parkinson's Disease Foundation put the number of American citizens suffering from this disease at more than 1.5 million individuals. Since the incidence of the disease increases with age (the most important risk factor), it is likely that the number of people suffering from PD will rise as improved health care lengthens the average life span.

Classically, PD is considered to be a motor system disease and its diagnosis is based on the presence of a set of cardinal motor signs (e.g. rigidity, bradykinesia, rest tremor and postural reflex disturbance). These symptoms of PD mainly result from the progressive degeneration of dopamine neurons of the substantia nigra pars compacta (SNc) that project predominantly to the striatum (Hirsch et al. 1988), a fact that contributes to the prevailing view that the basal ganglia are mainly concerned with motor control functions (Heikkila et al. 1989). More recently, an increasing amount of evidence has suggested that this system is also critically involved in learning and memory processes (Brown et al. 1997), as indicated by the fact that many cognitive impairments, including memory deficits, occur during the early stage of PD even before the development of its classical symptoms (Dubois and Pillon 1997; Owen et al. 1995). The non-motor symptoms that include cognitive deficits can be more important than the motor deficits to determine the patients' quality of life and represent an important factor to determine the need for nursing home care.

On the other hand, animal models are an invaluable tool for studying the pathogenesis and progression of human diseases, as well as for testing new therapeutic intervention strategies. PD is one of many human diseases which do not appear to have arisen spontaneously in animals. The characteristic features of the disease can, however, be more or less faithfully mimicked in animals through genetic approaches and the administration of various neurotoxic agents that interfere with dopaminergic neurotransmission. Despite the recent discovery of mutations in the alpha-synuclein gene (and some other genes) in a few PD patients that has led to the development of gene-based PD models (von Bohlen und Halbach et al. 2004), the administration of different neurotoxins such as 6-hydroxydopamine (6-OHDA) and 1-methyl-4-phenyl-1,2,3,6,-tetrahydropyridine (MPTP), which disrupt or destroy the dopaminergic system, remains the most widely used animal model for the study of PD. Although these models have undoubtedly contributed to a better understanding of many features of PD, most studies have focused on the ability of these models to induce nigrostriatal pathway damage and motor alterations associated with advanced phases of PD. However, until recently, no well-accepted model of the early phase of PD was available in the literature. The present review seeks to document these challenges using our earlier review (Da Cunha et al. 2002) as a basis for integrating the subsequent behavioral and neurochemical studies showing that the intranigral infusion of MPTP into rats causes a partial loss of dopamine neurons in the SNc and depletion of striatal dopamine, resulting in sensory and memory deficits with no major motor impairments, thus representing a model of the early phase of PD.

Finally, the fact that most of the drugs currently available for the treatment of PD (such as levodopa) are more efficient in alleviating motor than cognitive impairments has led many researchers to postulate non-dopaminergic

mechanisms for the cognitive symptoms of this disease. Here, we will briefly review clinical and non-clinical studies evaluating the potential of caffeine and other adenosine receptor antagonists to restore defective learning and memory processes in PD.

## COGNITIVE IMPAIRMENTS IN PARKINSON'S DISEASE

In addition to the characteristic motor symptoms, subtle cognitive impairments can be observed even during the early phases of PD (Dubois and Pillon 1997; Bosboom et al. 2004). They comprise a dysexecutive syndrome that includes attentional and working memory impairments accompanied by secondary deficits in the internal representation of visuospatial stimuli and in the use of declarative memory storage (Bradley 1989; Owen et al. 1993; Dubois and Pillon 1997; Tamaru 1997; Bosboom et al. 2004). Skill and habit learning is also impaired in these patients (Knowlton et al. 1996). Almost one-third of patients may eventually progress to dementia (Aarsland et al. 1996).

Dysexecutive syndrome represents the core of the cognitive impairments and dementia observed in PD, and appears even during early stages of the disease (Dubois and Pillon 1997; Tamaru, 1997; Bosboom et al. 2004; Owen 2004; Zgaljardic et al. 2004). Executive function describes a wide range of cognitive functions required for goal-directed, adaptive behavior in response to new, challenging environmental situations, including planning, task management, attention, inhibition, monitoring, and coding. All of these functions are attributable to the prefrontal cortex and therefore, PD cognitive disabilities resemble cognitive deficits found in frontal cortex patients (Tamaru 1997; Marie et al. 1999; Owen 2004).

A recent positron emission tomography study by Aalto et al. (2005) has shown increased dopamine release in the frontal cortex of human subjects performing a working memory task. Working memory (Stebbins et al. 1999; Marie and Defer 2003), especially spatial working memory (Pillon et al. 1996, 1997; Owen et al. 1997), fails in non-demented PD patients. The articulatory (verbal-phonological) component of the working memory is usually preserved, but when a verbal working memory task demands more attention, a deficiency is also observed in these patients (Moreaud et al. 1997; Owen 2004). These impairments are possibly the consequence of failure of the central executive component that manages the short-term memory. Thus, these impairments appear when the working memory tasks present a higher demand on executive functions such as planning and attention shifting (Bosboom et al. 2004).

Many studies have tested whether PD patients, who are known to have a striatal depletion of dopamine, present non-declarative learning and memory deficits (Bondi and Kaszniak 1991). These patients fail to improve mirror



reading of words that appeared only once during the test, an impairment attributable to a skill learning deficit (Thomas et al. 1996; Koenig et al. 1999). PD patients have been shown to present impaired skill learning not only for visuoperceptual but also for motor skill tasks such as puzzle assembly, pressing specific keys on a computer keyboard in response to a stimulus presented on the computer screen, and drawing lines in hidden mazes (Bondi and Kaszniak 1991; Thomas et al. 1996; Moreaud et al. 1997). Many deficits of PD patients in performing non-declarative tasks rely on the initial learning phase (Dujardin and Laurent 2003). On the other hand, there is no consensus about whether PD spares declarative memory (Thomas et al. 1996; Bondi and Kaszniak 1991). PD patients are generally not impaired to encode and store consolidated new information, but they present difficulties in retrieving this information, particularly when they have to self-initiate remembering strategies (Dujardin and Laurent 2003). A failure in executive functions may explain this deficit. However, the non-intentional and automatic nature of a non-declarative task, such as learning a list of words or matching pairs of words, may also determine whether it can be learned normally or not by PD patients (Faglioni et al. 1995, 1997; Roncacci et al. 1996). Some authors explain the declarative deficits reported in some studies involving PD patients as resulting from the fact that they require a larger number of repetitions of the task to translate non-declarative (procedural) into declarative knowledge (Pascual-Leone et al. 1993).

Habits are by definition stimulus-response associations that are unconsciously learned through repetitively rewarded experiences. The main difficulty to model a habit task is to guarantee that the subjects will not respond consciously in order to receive the reward. One of the main well-designed studies planned to test whether non-demented PD patients are impaired in stimulus-response habit learning used a probabilistic classification task (Knowlton et al. 1996). The probabilistic structure of the task permitted the subjects to learn the task unconsciously by trial-and-error. PD patients scored worse than Alzheimer's disease patients and healthy subjects, but when asked about it, they remembered to have participated in the previous training sessions. Alzheimer's disease patients, on the other hand, learned this task like healthy subjects, but barely remembered the training episode. This study supports the double dissociation proposed for the medial temporal- and basal ganglia-mediated declarative (episodic) and non-declarative (implicit habit learning) memory systems, respectively (Packard and Knowlton 2002).

The risk of developing dementia is up to six times higher in PD patients than in healthy subjects of the same age (Aarsland et al. 1996). The core of the impairments lies in executive functions (e.g. set-shifting) (Girotti 1986). Mood (e.g. depression), and psychotic (e.g. visual hallucinations) symptoms are also common in demented PD patients. Other common im-

pairments include visuospatial and visuoconstructive skills. Speech and language difficulties, such as naming and sentence comprehension, are also common. Furthermore, poor verbal fluency would be predictive of dementia in PD. Declarative memory impairments are present, but are less severe, as compared to Alzheimer's disease. There is a deficit in free recall, but it can be compensated for by semantic cueing. Furthermore, PD patients have more problems to recall than to encode declarative memories, i.e., their impairment relies on difficulties in activating processes involved in the functional use of memory storages, probably as a consequence of the dysexecutive syndrome. Recognition memory is relatively intact (Bosboom et al. 2004). Some of these cognitive impairments, especially attention impairment, are aggravated by a degeneration of cholinergic neurons in the nucleus basalis of Meynert and of noradrenaline neurons in the locus ceruleus that also occur in PD. On the other hand, impairments in declarative memory, aphasia and apraxia, when present, are related to cortical pathology indicative of Alzheimer's disease or Lewy body dementia. Regarding the last co-morbidity, it is noteworthy how many characteristics of PD dementia resemble Lewy body dementia. Additionally, postmortem studies have revealed that many Lewy body disease patients had been wrongly diagnosed in life as having PD patients and many PD patients develop Lewy body disease later on (Zgaljardic et al. 2004).

### **THE BASAL GANGLIA SYSTEM OF LEARNING AND MEMORY**

As important as knowing the cause of PD is to know the normal function of the brain components affected by this disease. Dopamine neurons of the SNc modulate the basal ganglia, which are composed of the caudate nucleus and putamen (altogether called striatum) and the globus pallidus. Due to their reciprocal connections with these core structures of the basal ganglia, the substantia nigra, ventral tegmental area and the subthalamic nucleus are considered to be associated basal ganglia structures (Alexander and Crutcher 1990). Neurons from all parts of the neocortex project to the striatum. Striatal neurons, in turn, project to the globus pallidus or to the substantia nigra pars reticulata which projects to the ventrolateral thalamus that, in turn, projects back to the frontal cortex (Alexander and Crutcher 1990). Therefore, the activity of sensory and motor parts of the cortex affects the activity of the basal ganglia that, in turn, modulate the activity of motor and cognitive parts of the frontal cortex. The positive modulation exerted by glutamate thalamic neurons on the frontal cortex is under inhibitory control of GABAergic neurons of the globus pallidus and the substantia nigra pars reticulata. This inhibition can be either blocked by a direct pathway or increased by an indirect pathway of neurons that arise in the striatum. Midbrain dopamine neurons play a dual

role in the modulation of the activity of these striatal neurons. Acting on D1-like or D2-like dopamine receptors, the dopamine released by these neurons activates the direct pathway and inhibits the indirect pathway, respectively. Both actions result in a positive modulation of the motor and cognitive functions of the frontal cortex (Alexander et al. 1986). According to this view, it is clear that the loss of midbrain dopamine neurons that occurs in PD results in the impairment of both motor and cognitive functions.

How does the decrease of dopamine concentration in the striatum, and its consequent decrease in the positive modulation exerted by the basal ganglia loop on the frontal cortex, causes the cognitive impairments observed in PD? Let us start with motor skills and habit learning. The primary motor cortex, supplementary motor area and somatosensory cortex neurons directly control the firing of spinal motor neurons, leading to consciously willed movements. Motor programs are the orchestrated sequences of commands to functional groups of muscles that govern movements at or around the joints (Alexander and Crutcher 1990). Where are these motor programs encoded and stored? The striatum is in a strategic position to participate in the encoding of such motor programs that will constitute the framework of the motor skills and habits (Packard and Knowlton 2002). The ability to perform a skill demands the coordinated activity of muscle groups from different parts of the body, the continuous integration of information about the contraction state of these muscles, and the visual follow-up of the movement in order to make fine adjustments for proper movements. Habit learning consists of increasing the probability that a sensory stimulus triggers a motor program designed for a particular behavioral response (White and McDonald 2002). As mentioned above, both sensory and motor regions of the entire cortex project to the striatum. The primary motor cortex also presents a somatotopic organization. Inputs from regions of the primary motor (MI) and sensory (SI) cortex that represent the same part of the body send projections to the same region within the striatum (Flaherty and Graybiel 1998). However, while the cortical regions form a single and continuous representation of the entire body, the representation of these areas of the body in the striatum is broken into a mosaic and is redundant, i.e., each part of the body is represented by multiple striatal units called *matrisomes*. After these somatosensorimotor inputs are processed in the striatum, the multiple *matrisomes* representing the same body parts send overlapping projections to the globus pallidus, where a unique and continuous representation of the body is restored (Graybiel 1998). Primary cortex regions for other sensory modalities, i.e., vision, hearing and smell, also send projections to the striatum (Calabresi et al. 1996). Notice that the multiple mosaic representation of sensory and motor information in the striatum allows the association of different stimuli with the activation of movement sequences involving different parts of the body. The capacity of dopamine neurons to either

inhibit or stimulate the basal-cortical output and to induce firing-dependent plasticity in the corticostriatal synapses enables this system to form experience-driven stimulus-response programs that are the basis of skills and habit learning (Graybiel et al. 1994; Graybiel 1998).

Working memory and executive functions, also affected in PD, depend on the activity of the prefrontal cortex (Dirnberger et al. 2005). There are loops integrating the dorsolateral and the orbitofrontal areas of the prefrontal cortex with the basal ganglia (Alexander et al. 1986). A study by Postle and D'Esposito (1999) showed increased activity of these cortical regions and the dorsal striatum when subjects were performing spatial working memory tasks. Furthermore, Lewis et al. (2003) reported that cognitive impairments in early PD, including working memory, are accompanied by a reduced activity in the frontostriatal neural circuitry. The concept of working memory involves the integration and maintenance of information for its prospective use when selecting the appropriate behavior (Baddeley 2003). This process could involve the transformation of sensory cues into a code response. The prefrontal cortex is at the top hierarchy of the sensory and motor systems (Faw 2003). Like the striatum, it can receive information from all sensory modalities and control the motor output. While doing this, it works in consonance with basal ganglia loops. These corticobasal loops can run parallel subroutines that are unconsciously operated, while the prefrontal cortex is involved in solving conscious demands for the ongoing behavior. Like the striatum, the prefrontal cortex is also modulated by dopamine neurons arising in the midbrain (Costa et al. 2003). Therefore, it is easy to understand how the abnormal depletion of dopamine levels in these brain regions as observed in PD can affect working memory. In the same way, attention and other executive functions of the prefrontal cortex will be affected by dopamine depletion in the striatum and prefrontal cortex (Dubois and Pillon 1997; Owen 2004).

### **MPTP-LESIONED RAT AS AN ANIMAL MODEL OF COGNITIVE IMPAIRMENTS OBSERVED DURING THE EARLY PHASE OF PARKINSON'S DISEASE**

In the early 1980s, the dopaminergic neurotoxin MPTP was accidentally discovered when a group of young drug addicts in California developed an idiopathic parkinsonian syndrome. Investigation revealed that the syndrome was caused by self-administration of a "synthetic heroin" analogue that had been contaminated with a byproduct (MPTP) during manufacturing (Davis et al. 1979; Langston et al. 1983). At present, MPTP represents the most important and most frequently used neurotoxin applied to animal models of PD, presenting advantages over all other toxic PD models since it causes a specific

loss of dopamine neurons and induces symptoms identical to PD in humans (Przedborski and Vila 2003).

MPTP is highly lipophilic and readily crosses the blood-brain barrier. It is then converted in the glia into its active metabolite, 1-methyl-4-phenylpyridinium cation (MPP<sup>+</sup>), by monoamine oxidase B, an enzyme involved in catecholamine degradation. MPP<sup>+</sup> is taken up by the dopamine transporter and accumulates in dopamine neurons. Absorbed MPP<sup>+</sup> concentrates in mitochondria where it inhibits complex I of the electron transport chain, thereby reducing ATP generation and causing the production of reactive oxygen species, inducing apoptotic death of dopamine neurons (see Beal 2001).

MPTP can be given in a variety of regimens (e.g. gavage or stereotactic injection), but the most common and reproducible form is systemic administration (e.g. subcutaneous, intravenous, intraperitoneal or intramuscular) (Przedborski et al. 2001). In primates such as humans, monkeys and baboons, MPTP causes irreversible and severe parkinsonian symptoms that are indistinguishable from those of sporadic PD (Bezard et al. 1997, 2001; Przedborski et al. 2001). In contrast to primates, rodents are less sensitive to MPTP toxicity (Schmidt and Ferger 2001). Nevertheless, the C57 black mouse strain was found to be sensitive to systemic injection of MPTP and was significantly more selective than other mouse strains in terms of affecting mesencephalic dopamine neurons (Sedelis et al. 2000, 2001; Schmidt and Ferger 2001). Therefore, because of the economical, logistic and ethical constraints related to experimental research in primates, the MPTP mouse model has become the most commonly used animal model of PD to study neuropathological and neurochemical changes (Schmidt and Ferger 2001; Schober 2004).

On the other hand, few studies have used MPTP-lesioned rats. The main reason for this is that shortly after the discovery that MPTP causes a parkinsonian syndrome when systemically administered to humans and non-human primates (Langston et al. 1983), no susceptibility of rats to MPTP has been reported when the drug was administered systemically (Chiueh et al. 1984; Kalaria et al. 1987). The conspicuous insensitivity of rats to MPTP toxicity may be related to a species-specific MPTP metabolism and/or sequestration of MPP<sup>+</sup>, which could be different in rats compared to mice and monkeys (Johannessen et al. 1985; Kalaria et al. 1987; Schmidt and Ferger 2001). For this reason some authors (see Schmidt and Ferger 2001; Schober 2004) did not recommend rats for MPTP research. Recently, this view has been re-evaluated following the findings that the infusion of MPTP directly into the rat SNc causes a partial loss of dopamine neurons and depletion of striatal dopamine that result in sensory and memory deficits (Harik et al. 1987; Da Cunha et al. 2001, 2002).

Rats with SNc lesion induced by intracerebral administration of 6-OHDA have been successfully used to study the physiology of nigrostriatal pathway

disruption, and have become a very popular model of motor alterations related to advanced phases of PD characterized by gross motor alterations (Ungerstedt 1968; Shwartzing and Huston 1996). However, until recently, no well-accepted model of the early phase of PD was available in the literature. Such model is very important to study the mechanisms of the deficits characteristic of this phase and to screen putative drugs able to improve and maintain the quality of life of PD patients during a phase when they can better benefit from treatment and be more effectively cared for.

Since the early phase of PD is characterized by only partial lesion of the SNc (less than 70% cell loss), mild motor impairment and cognitive deficits, we have proposed that bilaterally MPTP-lesioned rats represent a good model of this early phase of the disease. This model of PD seems to be appropriate for this purpose because, in contrast to unilaterally SNc-lesioned rats, animals with bilateral lesions do not present gross motor alterations that would otherwise confound the interpretation of poor scores in memory tasks as indicative of cognitive impairment. Extensive tests have shown that 3 weeks after surgery these animals present no significant sensorimotor disturbances. At this time, the animals are not aphagic or adipsic and their exploratory behavior scored in an open field or in a shuttle-box, as well as their time of permanence in a rota-rod, is normal (Da Cunha et al. 2001; Miyoshi et al. 2002). The reason for this lack of motor impairment is probably due to a combination of the following factors: 1) the partial nature of the SNc lesion and striatal dopamine depletion induced by MPTP, 2) a compensatory neural plasticity in the basal ganglia circuit during the 3 weeks after surgery, and 3) the bilateral nature of the lesion.

Since bilateral lesion of the SNc by MPTP does not cause motor impairments in rats, the next step was to study what kinds of memory are affected in these animals. Nowadays, it is generally accepted that there are multiple memory systems. Two of the most studied examples are the hippocampal and the basal ganglia memory systems, which process and store information independently and in different styles. According to this view, the hippocampal system processes spatial-temporal memories involving relations among environmental cues (e.g. episodic memory in humans), while the basal ganglia system is involved in habit learning in which a single stimulus is repeatedly associated with a response (Packard and Knowlton 2002; McDonald et al. 2004; White 2004). As pointed out above, there is evidence to support the idea that PD patients present deficits to learn habit tasks (Knowlton et al. 1996; Dubois and Pillon 1997). Other studies consistently reported that PD patients are impaired in spatial working memory and other central executive functions (Owen et al. 1997; Owen 2004). Our studies using MPTP-induced SNc-lesioned rats as a model of PD are consistent with this view. Two different versions of the Morris water maze task proved to be particularly suitable

to test spatial memory or habit learning. In the spatial version, rats learn to escape to a submersed platform that is maintained in the same location in the water maze from the beginning to the end of the experiment. In this case, the animals need to make associations among the spatial environmental cues in order to form a cognitive map that helps them to find the platform (Morris et al. 1982). In the habit version, the animals learn to associate the position of a white ball attached to the platform and protruding above the water. The position of the platform is changed randomly among trials. In this case, a single stimulus (the ball) is repeatedly associated with a response of approaching the platform. Spatial memory critically depends on the integrity of the hippocampus but not of the dorsal striatum, whereas habit learning critically depends on the integrity of the dorsal striatum but not of the hippocampus (Packard and McGaugh 1992; White and McDonald 2002).

Studies from our laboratory have shown that SNc lesion does not affect learning or memory in the spatial version of the water maze, but hippocampal inactivation with lidocaine prevents animals from finding the submersed platform. An opposite response was observed with the cued version, since SNc lesion, but not hippocampal inactivation, impairs learning and memory. No significant interaction was observed between the SNc lesion and hippocampal inactivation conditions in terms of affecting scores in the spatial or in the cued version of the water maze (Miyoshi et al. 2002; Da Cunha et al. 2002). These results suggest that the nigrostriatal pathway is an essential part of the basal ganglia memory system which processes stimulus-response habit learning and works independently of the hippocampal memory system which processes spatial/relational memories.

MPTP rats also presented a deficit in the working memory version of the Morris water maze (Miyoshi et al. 2002). In this version, the position of the platform is maintained constant during four subsequent trials performed on the same day, but its position is changed on each subsequent training day. With this protocol, the animal cannot use the previous day reference memory to find the platform and, thus, has to use its working memory of the previous trial to find it. Another rat learning and memory task affected by bilateral lesion of the SNc is two-way active avoidance (Da Cunha et al. 2001). This task models multiple kinds of memory, but habit learning is an important component of this task, in which a single cue (a sound signal) is repeatedly associated with a foot shock that can be avoided by crossing to the opposite side of a shuttle box. The impairing effect of nonspecific (electrolytic) SNc lesion on this task has been previously reported by Mitcham and Thomas (1972). The dependency to learn this task on the integrity of the dorsal striatum has also been reported in other studies (Kirkby and Polgar 1974; El Massioui and Delatour 1997).

The deficit of MPTP rats has also been observed in another working

memory task named delayed alternation in a Y-maze (Braga et al. 2005). In this task, the rats have to alternate between two arms of a Y-maze in order to find a food pellet. During the 20-s intertrial intervals the animals have to maintain in their working memory which arm they had previously visited in order to alternate correctly. SNc lesion with MPTP increased the number of errors in both pretrained and naive rats. In another study, we have shown that the left SNc seemed to be more critical than the right SNc for the performance of the working memory of rats in a version of the Morris water maze (Bellissimo et al. 2004).

### **EFFECTS OF DOPAMINERGIC DRUGS ON THE MPTP RAT MODEL OF MEMORY IMPAIRMENTS RELATED TO PD**

Controversy exists regarding the dopaminergic nature of the cognitive impairments in PD. Since neurons producing other neurotransmitters (e.g. acetylcholine, serotonin, noradrenaline) are also reported to degenerate in this disease (Braak et al. 2003), some authors consider that they may cause some cognitive and behavioral dysfunction, especially in demented patients (Dujardin and Laurent 2003; Zgaljardic et al. 2004). On the other hand, other investigators have reported a correlation between the loss of dopamine neurons of the nigrostriatal pathway and the degree of dementia (Rinne et al. 1999) and performance in neuropsychological tests in PD patients (Marie et al. 1999; Bruck et al. 2001). Animal models can contribute to establish the specific implications of each neurotransmitter system in the cognitive impairments of PD. The role of dopamine can be studied by using models that are specific for dopamine depletion, such as the MPTP models, and by investigating the effects of dopamine receptor antagonists on cognition.

Ogren and Archer (1994) reported that haloperidol and other dopamine receptor antagonists impair acquisition and retention in the two-way active avoidance task, indicating that the performance of this task depends on normal dopaminergic neurotransmission. The sensitivity of this task to SNc lesions and striatal dopamine manipulations and the facility to perform this task – only two sessions are necessary in an automated apparatus – make it particularly suitable to test drugs with a potential to treat the cognitive symptoms of PD. Thus, we tested the effect of the most efficient drug used in the treatment of the motor symptoms of PD, levodopa, on SNc-lesioned rats. The administration of benserazide/levodopa to MPTP-lesioned rats, at a dose that restores the striatal level of dopamine, did not reverse the MPTP-induced learning and memory impairment (Gevaerd et al. 2001a).

In humans, the beneficial effect of levodopa on improving the cognitive function affected in PD is controversial. While some studies indicate an im-



provement of cognitive functions in PD patients treated with levodopa (Beardley and Puletti 1971; Loranger et al. 1972; Girotti et al. 1986; Cooper et al. 1992; Cools et al. 2001), others have shown that this treatment may cause no or only mild improvement (Pillon et al. 1989; Growdon et al. 1998; Rektorova et al. 2005), or may even aggravate PD cognitive impairments (Huber et al. 1989; Poewe et al. 1991; Prasher and Findley 1991; Cools et al. 2001). Gotham et al. (1988) proposed that the detrimental effects of levodopa observed in some cognitive tasks may be due to excessively high concentrations of dopamine in areas such as the prefrontal cortex where dopamine depletion is less severe. We showed that this was the case for MPTP rats treated with levodopa (Gevaerd et al. 2001a). The levodopa dose necessary to restore a normal striatal level of dopamine caused a large increase of dopamine levels in extrastriatal brain regions. Therefore, that study proves that, at least for the MPTP rat model of PD, levodopa therapy is not effective in improving the observed memory impairment because it appears to tilt the balance between dopamine levels in the striatum and in extrastriatal regions such as the prefrontal cortex (and also limbic structures), resulting in a cognitive deficit. In accordance with this idea, a recent work by Bruck et al. (2005) showed that the finding of early phase PD patients scoring poorly in tests measuring frontal lobe functions was positively correlated with increased cortical Fdopa uptake.

Furthermore, the various cognitive impairments of PD may depend on different brain areas that are differently depleted of dopamine, such as the dorsal striatum and prefrontal cortex. A study by Swainson et al. (2000) has shown that non-medicated PD patients performed better than medicated patients in a reversal test that depends on the striatum and ventral frontal cortex. However, the same patients performed worse than medicated patients in a spatial recognition memory task that depends on the dorsolateral frontal cortex. The authors suggested that the levodopa treatment overdosed the dorsolateral frontal cortex, which was less affected by the disease, at the same time that it restored a normal level of dopamine in the striatum and ventral frontal cortex. Cools et al. (2001) reported similar results showing that levodopa-treated patients can perform better or worse in tasks depending on different components of the frontostriatal circuitry. In that study, levodopa withdrawal improved performance in probabilistic reversal learning, a task that depends on the orbitofrontal cortex, ventral frontal cortex, and ventral striatum. However, levodopa withdrawal impaired performance in a set-shifting task, which depends on the dorsolateral frontal cortex and dorsal caudate nucleus.

Therefore, although the above studies discourage the use of levodopa therapy to treat some PD cognitive symptoms, it does not imply that these cognitive symptoms are not related to the degeneration of the nigrostriatal pathway. In addition to the observed impairment in two-way active avoid-

ance learning caused by the depletion of striatal dopamine in MPTP-lesioned rats, other important findings suggest that mnemonic processes depend on a normal level of stimulation of the striatal dopamine receptors. Packard and White (1991) and Packard and McGaugh (1994) showed improved cognitive performance after intrastriatal administration of a D2 receptor agonist to rats. Also, Schneider et al. (1994) observed a cognitive improving effect of the systemic administration of a D1-receptor agonist to MPTP-lesioned monkeys. D1-receptor agonists have also been reported to release acetylcholine in the frontal cortex and dorsal striatum and to improve cognitive performance in rats (Steele et al. 1997). More recently, other authors have suggested that D1 receptor agonists can be useful in the treatment of cognitive impairments of PD (Nichols and Lewis 2004; Salmi et al. 2004), and it would be interesting to test them in an animal model such as the MPTP rat model used here.

The failure of levodopa to reverse the memory impairment of MPTP rats in the two-way active avoidance task is likely to be related, at least in part, to the failure of this treatment to improve the cognitive impairments of PD patients, as mentioned above. Since this was equally observed in some clinical studies and in our rat model of memory impairments related to PD, these results encouraged the use of the rat MPTP model in studies on alternative drug therapies for the treatment of the cognitive impairments of PD.

### **EFFECTS OF ADENOSINE RECEPTOR ANTAGONISTS ON THE MPTP RAT MODEL OF MEMORY IMPAIRMENTS RELATED TO PD**

It is well known that adenosine receptors are densely expressed in the striatum and exert a modulatory influence on dopamine neurotransmission (Moreau and Huber 1999; Svenningsson et al. 1999). The understanding of the role of adenosine in basal ganglia and its anatomical and functional relationship with the striatal dopamine D1 and D2 receptors has increased over the last years, providing evidence of an antagonistic interaction between A(2A)/D2 and A(1)/D1 receptors in the striatum (Fuxe et al. 1998; Franco et al. 2000). Moreover, neuroprotective properties of caffeine and A(2A) adenosine receptor antagonists have been reported for dopamine neurons in the SNc (Chen et al. 2001). Furthermore, adenosine receptor-related drugs seem to be promising candidates for the symptomatic treatment of PD, since there is evidence that caffeine directly increases dopamine release from striatal nerve terminals (Okada 1997). This dopamine-releasing effect of caffeine was also observed with the A(2A) adenosine receptor antagonist, ZM 241385, in striatal synaptosomes (Da Cunha et al. 2002). All these putative anti-Parkinson effects may explain the finding that the risk of PD is significantly reduced among coffee drinkers (Paganini-Hill 2001). Based on these promising effects, adenosine receptor

antagonists are being pursued as putative drugs to treat PD (Ferre et al. 2001; Wardas 2001).

Caffeine has also been reported to improve learning and memory in a variety of animal (Pare 1961; Molinengo et al. 1995; Cestari and Castellano 1996; Howell et al. 1997) and human studies (Riedel et al. 1995; Pollina and Calev 1997). In our laboratory we also demonstrated that pretraining and pre-test systemic administration of caffeine can improve the memory of rats in various tasks (Angelucci et al. 1999, 2002; Prediger and Takahashi 2005; Prediger et al. 2005a,b,c). Due to the failure of levodopa to reverse the memory impairments caused by SNc lesion in rats, we decided to test whether caffeine is effective to do so. Caffeine (0.1 to 0.3 mg/kg, i.p.) reverses the impairing effect of the MPTP-induced SNc lesion of rats on the avoidance scores in the training and test sessions of a two-way active avoidance task (Gevaerd et al., 2001b). This result suggests that the effects of caffeine and other adenosine receptor antagonists acting on the striatal dopaminergic system can be useful to restore defective learning and memory processes in PD.

### CONCLUDING REMARKS

The data reviewed here indicate the successful refinement of an experimental model of PD, and describe behavioral tests that can be used in rodents to study early PD-related cognitive deficits. Because an animal model cannot provide the full range of effects of such complex human neurodegenerative disease, a rodent model by injecting MPTP into the SNc was constructed by drawing from various sources, which included tests of spatial memory, working memory and habit learning. Measures of cognitive impairments in the absence of compromising sensory and/or motor disabilities have been obtained and tentatively related to current theoretical constructs of human cognition. The studies reviewed here stress the critical role of the dopaminergic nigrostriatal pathway as an essential element of the basal ganglia neural circuit, participating in specific learning and memory processes in the brain. The proposed MPTP rat model of PD-related memory impairments proved to be appropriate for studies of the neural circuits supporting this cognitive pathology. Moreover, our studies consistently suggest that adenosine receptor antagonists (e.g. caffeine), previously reported as putative drugs for treating the motor symptoms of PD, are also promising drugs to treat the cognitive impairments related to this disease. Considering the failure of levodopa to treat these cognitive disabilities, the development of a new class of drugs for incorporation into the pharmacological options for the treatment of PD is noteworthy. Certainly, additional studies are necessary to better understand the neurobiological substrates of early cognitive impairment in PD, as well as the development of novel therapeutic strategies for this neurodegenerative disorder.

## REFERENCES

- Aalto S, Bruck A, Laine M, Nagren K, Rinne JO (2005) Frontal and temporal dopamine release during working memory and attention tasks in healthy humans: a positron emission tomography study using the high-affinity dopamine D-2 receptor ligand [C-11]FLB 457. *J Neurosci* 25:2471-2477
- Aarsland D, Tandberg E, Larsen JP, Cummings JL (1996) Frequency of dementia in Parkinson disease. *Arch Neurol* 53:538-542
- Alexander GE, Crutcher MD (1990) Functional architecture of basal ganglia circuits: neural substrates of parallel processing. *Trends Neurosci* 13:266-271
- Alexander GE, DeLong MR, Strick PL (1986) Parallel organization of functionally segregated circuits linking basal ganglia and cortex. *Annu Rev Neurosci* 9:357-381
- Angelucci ME, Vital MA, Cesario C, Zadusky CR, Rosalen PL, Da Cunha C (1999) The effect of caffeine in animal models of learning and memory. *Eur J Pharmacol* 373:135-140
- Angelucci MEM, Cesario C, Hiroi RH, Rosalen P, Da Cunha C (2002) The effect of caffeine on learning and memory of the Morris water maze. *Braz J Med Biol Res* 35:1201-1208
- Baddeley A (2003) Working memory: looking back and looking forward. *Nat Rev Neurosci* 4:829-839
- Beal MF (2001) Experimental models of Parkinson's disease. *Nat Rev Neurosci* 2:325-334
- Beardsley JV, Puletti F (1971) Personality (MMPI) and cognitive (WAIS) changes after levodopa treatment. *Arch Neurol* 25:145-150
- Bellissimo MI, Kouzmine I, Ferro MM, Oliveira BH, Canteras NS, Da Cunha C (2004) Is the unilateral lesion of the left substantia nigra pars compacta sufficient to induce working memory impairment in rats? *Neurobiol Learning Memory* 82:150-158
- Bezard E, Dovero S, Prunier C, Ravenscroft P, Chalon S, Guilloteau D, Crossman AR, Bioulac B, Brotchie JM, Gross CE (2001) Relationship between the appearance of symptoms and the level of nigrostriatal degeneration in a progressive 1-methyl-4-phenyl-1,2,3,6-tetrahydropyridine-lesioned macaque model of Parkinson's disease. *J Neurosci* 21:6853-6861
- Bezard E, Imbert C, Deloire X, Bioulac B, Gross CE (1997) A chronic MPTP model reproducing the slow evolution of Parkinson's disease: evolution of motor symptoms in the monkey. *Brain Res* 766:107-112
- Bondi MW, Kaszniak AW (1991) Implicit and explicit memory in Alzheimer's disease and Parkinson's disease. *J Clin Exp Neuropsychol* 13:339-358
- Bosboom JL, Stoffers D, Wolters ECh (2004) Cognitive dysfunction and dementia in Parkinson's disease. *J Neural Transm* 111:1303-1315
- Braak H, Del Tredici K, Rub U, de Vos RA, Jansen Steur EN, Braak E (2003) Staging of brain pathology related to sporadic Parkinson's disease. *Neurobiol Aging* 24:197-211
- Bradley VA, Welch JL, Dick DJ (1989) Visuospatial working memory in Parkinson's disease. *J Neurol Neurosurg Psychiatry* 52:1228-1235
- Braga R, Kouzmine I, Canteras NS, Da Cunha C (2005) Lesion of the substantia nigra,

- pars compacta impairs delayed alternation in a Y-maze in rats. *Exp Neurol* 192:134-141
- Brown LL, Schneider JS, Lidsky TI (1997) Sensory and cognitive functions of the basal ganglia. *Curr Opin Neurobiol* 7:157-163
- Bruck A, Portin R, Lindell A, Laihinen A, Bergman J, Haaparanta M, Solin O, Rinne JO (2001) Positron emission tomography shows that impaired frontal lobe functioning in Parkinson's disease is related to dopaminergic hypofunction in the caudate nucleus. *Neurosci Lett* 311:81-84
- Calabresi P, Pisani A, Mercuri NB, Bernardi G (1996) The corticostriatal projection: from synaptic plasticity to dysfunctions of the basal ganglia. *Trends Neurosci* 19:19-24
- Cestari V, Castellano C (1996) Caffeine and cocaine interaction on memory consolidation in mice. *Arch Int Pharmacodyn Ther* 331:94-104
- Chen JF, Xu K, Petzer JP, Staal R, Xu YH, Beilstein M, Sonsalla PK, Castagnoli K, Castagnoli N Jr, Schwarzschild MA (2001) Neuroprotection by caffeine and A(2A) adenosine receptor inactivation in a model of Parkinson's disease. *J Neurosci* 21:RC143
- Cools R, Barker RA, Sahakain BJ, Robbins TW (2001) Enhanced or impaired cognitive function in Parkinson's disease as a function of dopaminergic medication and task demands. *Cerebral Cortex* 11:1136-1143
- Cooper JA, Sagar HJ, Doherty SM, Jordan N, Tidswell P, Sullivan EV (1992) Different effects of dopaminergic and anticholinergic therapies on cognitive and motor function in Parkinson's disease. *Brain* 115:1701-1725
- Costa A, Peppe A, Dell'Agnello G, Carlesimo GA, Murri L, Bonuccelli U, Caltagirone C (2003) Dopaminergic modulation of visual-spatial working memory in Parkinson's disease. *Dement Geriatr Cogn Disord* 15:55-66
- Da Cunha C, Angellucci MEM, Canteras NS, Wonnacott S, Takahashi RN (2002) The lesion of the rat substantia nigra pars compacta dopamine neurons as a model for Parkinson's disease memory disabilities. *Cell Mol Neurobiol* 22:227-237
- Da Cunha C, Gevaerd MS, Vital MA, Miyoshi E, Andreatini R, Silveira R, Takahashi RN, Canteras NS (2001) Memory disruption in rats with nigral lesions induced by MPTP: a model for early Parkinson's disease amnesia. *Behav Brain Res* 124:9-18
- Da Cunha C, Wietzikoski S, Wietzikoski EC, Miyoshi E, Ferro MM, Anselmo-Franci JA, Canteras NS (2003) Evidence for the substantia nigra pars compacta as an essential component of a memory system independent of the hippocampal memory system. *Neurobiol Learning Mem* 79:236-242
- Davis GC, Williams AC, Markey SP, Ebert MH, Caine ED, Reichert CM, Kopin IJ (1979) Chronic parkinsonism secondary to intravenous injection of meperidine analogues. *Psychiatry Res* 1:249-254
- Dirnberger G, Frith CD, Jahanshahi M (2005) Executive dysfunction in Parkinson's disease is associated with altered pallidal-frontal processing. *Neuroimage* 25:588-599
- Dubois B, Pillon B (1997) Cognitive deficits in Parkinson's disease. *J Neurol* 244:2-8
- Dujardin K, Laurent B (2003) Dysfunction of the human memory systems: role of the dopaminergic transmission. *Curr Opin Neurol* 16: S11-S16
- Duvoisin RC (1991) Parkinson's disease. Third Edition. Raven Press, New York

- El Massioui N, Delatour BV (1997) Contrasting effects of central nucleus of the amygdala and dorsal striatum lesions on active avoidance learning and its contextual modification. *Neurosci Res Comm* 21:103–111
- Faglioni P, Botti C, Scarpa M, Ferrari V, Saetti MC (1997) Learning and forgetting processes in Parkinson's disease: a model-based approach to disentangling storage, retention and retrieval contributions. *Neuropsychologia* 35:767-779
- Faglioni P, Scarpa M, Botti C, Ferrari V (1995) Parkinson's disease affects automatic and spares intentional verbal learning. A stochastic approach to explicit learning processes. *Cortex* 31:597-617
- Faw B (2003) Pre-frontal executive committee for perception, working memory, attention, long-term memory, motor control, and thinking: a tutorial review. *Conscious Cogn* 12:83-139
- Ferre S, Popoli P, Gimenez-Llort L, Rimondini R, Muller CE, Stromberg I, Ogren SO, Fuxe K (2001) Adenosine/dopamine interaction: implications for the treatment of Parkinson's disease. *J Neurosci* 21:235-241
- Flaherty AW, Graybiel AM (1998) Input-output organization of the sensorimotor striatum in the squirrel-monkey. *J Neurosci* 14:599-610
- Franco R, Ferre S, Agnati L, Torwinen M, Hillion J, Casado V, Lledo P, Zoli M, Lluis C, Fuxe K (2000) Evidence for adenosine/dopamine receptor interactions. Indications for heteromerization. *Neuropharmacology* 23:550–559
- Fuxe K, Ferre S, Zoli M, Agnati LF (1998) Integrated events in central dopamine transmission as analyzed at multiple levels. Evidence for intramembrane adenosine A2A/dopamine D2 and adenosine A1/dopamine D1 receptor interactions in basal ganglia. *Brain Res Brain Res Rev* 26:258–273
- Gevaerd MS, Miyoshi E, Silveira R, Canteras NS, Takahashi RN, Da Cunha C (2001a) L-Dopa restores striatal dopamine level but fails to reverse MPTP-induced memory deficits in rats. *Int J Neuropsychopharmacol* 4:361-370
- Gevaerd MS, Takahashi RN, Da Cunha C (2001b). Caffeine reverses the memory disruption induced by intra-nigral MPTP-injection in rats. *Brain Res Bull* 55:101-106
- Girotti F, Carella F, Grassi MP, Soliveri P, Marano R, Caraceni T (1986) Motor and cognitive performances of parkinsonian patients in the on and off phases of the disease. *J Neurol Neurosurg Psychiatry* 49:657–660
- Gotham AM, Brown RG, Marsden CD (1988) "Frontal" cognitive functions in patients with Parkinson's disease "on" and "off" levodopa. *Brain* 111:299–321
- Graybiel AM (1998) The basal ganglia and chunking of action repertoires. *Neurobiol Learn Mem* 70:119-36
- Growdon JH, Kiebertz K, McDermott MP, Panisset M, Friedman JH (1998) Levodopa improves motor function without impairing cognition in mild non-demented Parkinson's disease patients. *Parkinson Study Group. Neurology* 50:1327-1331
- Heikkila RE, Sonsalla PK, Duvoisin RC (1989) Biochemical models of Parkinson's disease. In: Boulton AA, Baker GB, Jurio AV (eds) *Neuromethods. Drugs as Tools in Neurotransmitter Research*, vol. 12, Human Press, New York, pp 351–384
- Hirsch E, Graybiel AM, Agid YA (1988) Melanized dopamine neurons are differentially susceptible to degeneration in Parkinson's disease. *Nature* 334:345-348
- Howell LL, Coffin VL, Spealman RD (1997) Behavioral and physiological effects of xanthines in nonhuman primates. *Psychopharmacology* 129:1-14

- Huber SJ, Shulman HG, Paulson GW, Shuttleworth EC (1989) Dose-dependent memory impairment in Parkinson's disease. *Neurology* 39:438-440
- Johannessen JN, Chiueh CC, Burns RS, Markey SP (1985) Differences in the metabolism of MPTP in the rodent and primate parallel differences in sensitivity to its neurotoxic effects. *Life Sci* 36:219-224
- Kirkby RJ, Polgar S (1974). Active avoidance in laboratory rat following lesions of dorsal or ventral caudate-nucleus. *Physiol Psychol* 2:301-306
- Knowlton BJ, Mangels JA, Squire LR (1996) A neostriatal habit learning system in humans. *Science* 273:1399-1402
- Koenig O, Thomas-Anterion C, Laurent B (1999) Procedural learning in Parkinson's disease: intact and impaired cognitive components. *Neuropsychologia* 37:1103-1109
- Langston JW, Ballard P, Tetrad JW, Irwin I (1983) Chronic Parkinsonism in humans due to a product of meperidine-analog synthesis. *Science* 219:979-980
- Lewis SJG, Dove A, Robbins TW, Barker RA, Owen AM (2003) Cognitive impairments in early Parkinson's disease are accompanied by reductions in activity in frontostriatal neural circuitry. *J Neurosci* 23:6351-6356
- Loranger AW, Goodell H, Lee JE, McDowell F (1972) Levodopa treatment of Parkinson's syndrome. Improved intellectual functioning. *Arch Gen Psychiatry* 26:163-168
- Marie RM, Barre L, Dupuy B, Viader F, Defer G, Baron JC (1999) Relationships between striatal dopamine denervation and frontal executive tests in Parkinson's disease. *Neurosci Lett* 260:77-80
- Marie RM, Defer G (2003) Working memory and dopamine: clinical and experimental clues. *Curr Opin Neurol* 16:S29-S35
- McDonald JR, Hong NS, Devan BD (2004) The challenges of understanding mammalian cognition and memory-based behaviours: an interactive learning and memory systems approach. *Neurosci Biobehav Rev* 28:719-745
- Mitcham JC, Thomas RK Jr (1972) Effects of substantia nigra and caudate-nucleus lesions on avoidance-learning in rats. *J Comp Physiol Psychol* 81:101-107
- Miyoshi E, Wietzikoski S, Camplessei M, Silveira R, Takahashi RN, Da Cunha C (2002) Impaired learning in a spatial working memory version and in a cued version of the water maze in rats with MPTP-induced mesencephalic dopaminergic lesions. *Brain Res Bull* 58:41-47
- Molinengo L, Orsetti M, Pastorello B, Scordo I, Ghi P (1995) Habituation of exploratory activity in rats: action of N6phenylisopropyladenosine, caffeine and their combination. *Prog Neuropsychopharmacol Biol Psychiatry* 19:1189-1200
- Moreau JL, Huber G (1999) Central adenosine A(2A) receptors: an overview. *Brain Res Brain Res Rev* 31:65-82
- Moreaud O, Fournet N, Roulin JL, Naegele B, Pellat J (1997) The phonological loop in medicated patients with Parkinson's disease: presence of phonological similarity and word length effects. *J Neurol Neurosurg Psychiatry* 62:609-611
- Morris RG, Garrud P, Rawlins JN, O'Keefe J (1982) Place navigation impaired in rats with hippocampal lesions. *Nature* 297:681-683
- Nichols DE, Lewis MM (2004) Mechanisms and issues relating to the use of D1-like dopamine receptor agonists for age-related illnesses: Parkinson's disease and memory and cognition. *Med Chem Res* 13:105-114

- Ogren SO, Archer T (1994) Effects of typical and atypical antipsychotic drugs on two-way active avoidance. Relationship to DA receptor blocking profile. *Psychopharmacology* 114:383-391
- Okada M, Kiryu K, Kawata Y, Mizuno K, Wada K, Tasaki H, Kaneko S (1997) Determination of the effects of caffeine and carbamazepine on striatal dopamine release by in vivo microdialysis. *Eur J Pharmacol* 321:181-188
- Owen AM (2004) Cognitive dysfunction in Parkinson's disease: the role of frontostriatal circuitry. *Neuroscientist* 10:525-537
- Owen AM, Beksinska M, James M, Leigh PN, Summers BA, Marsden CD, Quinn NP, Sahakian BJ, Robbins TW (1993) Visuospatial memory deficits at different stages of Parkinson's. *Neuropsychologia* 31:627-644
- Owen AM, Sahakian BJ, Hodges JR, Summers BA, Polkey CE, Robins TW (1995) Dopamine-dependent frontostriatal planning in early Parkinson's disease. *Neuropsychology* 9:126-140
- Packard MG, Knowlton BJ (2002) Learning and memory functions of the basal ganglia. *Annu Rev Neurosci* 25:563-593
- Packard MG, McGaugh JL (1992) Double dissociation of fornix and caudate nucleus lesions on acquisition of two water maze tasks: further evidence for multiple memory systems. *Behav Neurosci* 106:439-446
- Paganini-Hill A (2001) Risk factors for Parkinson's disease: the leisure world cohort study. *Neuroepidemiology* 20:118-124
- Pare W (1961) Effect of caffeine and seconal on a visual discrimination task. *J Comp Physiol Psychol* 54: 506-509
- Pascual-Leone A, Grafman J, Clark K, Stewart M, Massaquoi S, Lou J-S, Hallett M (1993) Procedural learning in Parkinson's disease and cerebellar degeneration. *Ann Neurol* 34:594-602
- Pillon B, Dubois B, Cusimano G, Bonnet AM, Lhermitte F, Agid Y (1989) Does cognitive impairment in Parkinson's disease result from non-dopaminergic lesions? *J Neurol Neurosurg Psychiatry* 52:201-206
- Pillon B, Ertle S, Deweer B, Bonnet AM, Vidailhet M, Dubois B (1997) Memory for spatial location in 'de novo' parkinsonian patients. *Neuropsychologia* 35:221-228
- Pillon B, Ertle S, Deweer B, Sarazin M, Agid Y, Dubois B (1996) Memory for spatial location is affected in Parkinson's disease. *Neuropsychologia* 34:77-85
- Poewe W, Berger W, Benke T, Schelosky L (1991) High-speed memory scanning in Parkinson's disease: adverse effects of levodopa. *Ann Neurol* 29:670-673
- Pollina DA, Calev A (1997) Amnesia associated with electroconvulsive therapy - progress in pharmacological prevention and treatment *CNS Drugs* 7:381-387
- Postle BR, D'Esposito M (1999) Dissociation of human caudate nucleus activity in spatial and nonspatial working memory: an event-related fMRI study. *Brain Res Cogn Brain Res* 8:107-115
- Prasher D, Findley L (1991) Dopaminergic induced changes in cognitive and motor processing in Parkinson's disease: an electrophysiological investigation. *J Neurol Neurosurg Psychiatry* 54:603-609
- Prediger RD, Batista LC, Takahashi RN (2005a) Caffeine reverses age-related deficits in olfactory discrimination and social recognition memory in rats. Involvement of adenosine A1 and A2A receptors. *Neurobiol Aging* 26:957-964



- Prediger RD, Da Cunha C, Takahashi RN (2005b) Antagonistic interaction between adenosine A2A and dopamine D2 receptors modulates the social recognition memory in reserpine-treated rats. *Behav Pharmacol* 16:209-218
- Prediger RD, Pamplona FA, Fernandes D, Takahashi RN (2005c) Caffeine improves spatial learning deficits in an animal model of attention deficit hyperactivity disorder (ADHD) – the spontaneously hypertensive rat (SHR). *Int J Neuropsychopharmacol* 8:583-594
- Prediger RD, Takahashi RN (2005) Modulation of short-term social memory in rats by adenosine A1 and A(2A) receptors. *Neurosci Lett* 376:160-165
- Przedborski S, Jackson-Lewis V, Naini AB, Jakowec M, Petzinger G, Miller R, Akram M (2001) The parkinsonian toxin 1-methyl-4-phenyl-1,2,3,6-tetrahydropyridine (MPTP): a technical review of its utility and safety. *J Neurochem* 76:1265-1274
- Przedborski S, Vila M (2003) The 1-methyl-4-phenyl-1,2,3,6-tetrahydropyridine mouse model: a tool to explore the pathogenesis of Parkinson's disease. *Ann NY Acad Sci* 991:189–198
- Rektorova I, Rektor I, Bares M, Dostal V, Ehler E, Fanfrdlova Z, Fiedler J, Klajblova H, Kulist'ak P, Ressner P, Svatova J, Urbanek K, Veliskova J (2005) Cognitive performance in people with Parkinson's disease and mild or moderate depression: effects of dopamine agonists in an add-on to L-dopa therapy. *Eur J Neurol* 12:9-15
- Riedel W, Hogervorst E, Lebox R, Verhey F, van Praag H, Jolles J (1995) Caffeine attenuates scopolamine-induced memory impairment in humans. *Psychopharmacology* 122:158-168
- Rinne JO, Rummukainen J, Paljarvi L, Rinne UK (1989) Dementia in Parkinson's disease is related to neuronal loss in the medial substantia nigra. *Ann Neurol* 26:47–50
- Roncacci S, Troisi E, Carlesimo GA, Nocentini U, Caltagirone C (1996) Implicit memory in parkinsonian patients: evidence for deficient skill learning. *Eur Neurol* 36:154-159
- Salmi P, Isacson R, Kull B (2004) Dihydropyridine - the first full dopamine D1 receptor agonist. *CNS Drug Rev* 10:230-242
- Schmidt N, Ferger B (2001) Neurochemical findings in the MPTP model of Parkinson's disease. *J Neural Transm* 108:1263–1282
- Schneider JS, Sun ZQ, Roeltgen DP (1994) Effects of dihydropyridine, a full dopamine D-1 receptor agonist, on delayed response performance in chronic low dose MPTP-treated monkeys. *Brain Res* 663:140-144
- Schober A (2004) Classic toxin-induced animal models of Parkinson's disease: 6-OHDA and MPTP. *Cell Tissue Res* 318:215-224
- Sedelis M, Hofele K, Auburger GW, Morgan S, Huston JP, Schwarting RK (2000) MPTP susceptibility in the mouse: behavioral, neurochemical, and histological analysis of gender and strain differences. *Behav Genet* 30:171-182
- Sedelis M, Schwarting RK, Huston JP (2001) Behavioral phenotyping of the MPTP mouse model of Parkinson's disease. *Behav Brain Res* 125:109-125
- Shwartzing R, Huston JP (1996) The unilateral 6-hydroxydopamine lesion model in behavioral brain research. Analysis of functional deficits, recovery and treatments. *Progr Neurobiol* 50:275-331
- Stebbins GT, Gabrieli JDE, Masciari F, Monti L, Goetz CG (1999) Delayed recognition

- memory in Parkinson's disease: a role for working memory? *Neuropsychologia* 37:503-510
- Steele TD, Hodges DB, Levesque TR, Locke KW (1997) D-1 agonist dihydrexidine releases acetylcholine and improves cognitive performance in rats. *Pharmacol Biochem Behav* 58:477-483
- Svenningsson P, Le Moine C, Fisone G, Fredholm BB (1999) Distribution, biochemistry and function of striatal adenosine A2A receptors. *Prog Neurobiol* 59:355-396
- Swainson R, Rogers RD, Sahakian BJ, Summers BA, Polkey CE, Robbins TW (2000) Probabilistic learning and reversal deficits in patients with Parkinson's disease or frontal or temporal lobe lesions: possible adverse effects of dopaminergic medication. *Neuropsychologia* 38:596-612
- Tamaru F (1997) Disturbances in higher function in Parkinson's disease. *Eur Neurol* 38:33-36
- Thomas V, Reymann JM, Lieury A, Allain H (1996) Assessment of procedural memory in Parkinson's disease. *Prog NeuroPsychopharmacol Biol Psychiatry* 20:641-650
- Ungerstedt U (1968) 6-Hydroxydopamine induced degeneration of central monoamine neurons. *Eur J Pharmacol* 5:107-110
- von Bohlen und Halbach O, Schober A, Krieglstein K (2004) Genes, proteins, and neurotoxins involved in Parkinson's disease. *Prog Neurobiol* 73:151-177
- Wardas J, Konieczny J, Lorenc-Koci E (2001) SCH 58261, an A(2A) adenosine receptor antagonist, counteracts parkinsonian-like muscle rigidity in rats. *Synapse* 41:160-171.
- White NM, McDonald RJ (2002) Multiple parallel memory systems in the brain of the rat. *Neurobiol Learn Mem* 77:125-184
- Zgaljardic DJ, Foldi NS, Borod JC (2004) Cognitive and behavioral dysfunction in Parkinson's disease: neurochemical and clinicopathological contributions. *J Neural Transm* 111:1287-1301

**ANEXO 2**



## Review

## Learning processing in the basal ganglia: A mosaic of broken mirrors

Claudio Da Cunha<sup>a,\*</sup>, Evelyn Claudia Wietzikoski<sup>a</sup>, Patrícia Dombrowski<sup>a</sup>, Mariza Bortolanza<sup>a</sup>,  
Lucélia Mendes Santos<sup>a</sup>, Suelen Lucio Boschen<sup>a</sup>, Edmar Miyoshi<sup>a,b</sup>

<sup>a</sup> Laboratório de Fisiologia e Farmacologia do Sistema Nervoso Central, Departamento de Farmacologia, UFPR, C.P. 19.031, 81.531-980 Curitiba PR, Brazil

<sup>b</sup> Departamento de Ciências Farmacêuticas, UEPG, Ponta Grossa, Brazil

## ARTICLE INFO

## Article history:

Received 16 May 2008

Received in revised form 1 October 2008

Accepted 2 October 2008

Available online 11 October 2008

## Keywords:

Basal ganglia  
Striatum  
Substantia nigra  
Associative learning  
Memory  
Cognition  
Dopamine  
Reinforcement  
Reward

## ABSTRACT

In the present review we propose a model to explain the role of the basal ganglia in sensorimotor and cognitive functions based on a growing body of behavioural, anatomical, physiological, and neurochemical evidence accumulated over the last decades. This model proposes that the body and its surrounding environment are represented in the striatum in a fragmented and repeated way, like a mosaic consisting of the fragmented images of broken mirrors. Each fragment forms a functional unit representing articulated parts of the body with motion properties, objects of the environment which the subject can approach or manipulate, and locations the subject can move to. These units integrate the sensory properties and movements related to them. The repeated and widespread distribution of such units amplifies the combinatorial power of the associations among them. These associations depend on the phasic release of dopamine in the striatum triggered by the saliency of stimuli and will be reinforced by the rewarding consequences of the actions related to them. Dopamine permits synaptic plasticity in the corticostriatal synapses. The striatal units encoding the same stimulus/action send convergent projections to the internal segment of the globus pallidus (GPi) and to the substantia nigra pars reticulata (SNr) that stimulate or hold the action through a thalamus–frontal cortex pathway. According to this model, this is how the basal ganglia select actions based on environmental stimuli and store adaptive associations as nondeclarative memories such as motor skills, habits, and memories formed by Pavlovian and instrumental conditioning.

© 2008 Elsevier B.V. All rights reserved.

## Contents

1. Introduction .....	158
2. The basal ganglia circuitry .....	158
3. The 'mosaic of broken mirrors' model .....	159
3.1. Breaking the mirrors: functional convergence and widespread repetition .....	159
3.2. Building functional units .....	159
3.2.1. Body parts .....	159
3.2.2. Objects .....	160
3.2.3. Locations .....	160
3.2.4. Other functional units of the striatum .....	162
3.3. Building associative units .....	162
3.3.1. Synaptic plasticity in the striatum .....	163
3.3.2. Dopamine-dependent synaptic plasticity .....	163
3.3.3. Novelty-driven reinforcement learning .....	163
3.3.4. Aversively motivated learning .....	164
3.4. Building action units .....	165
3.4.1. Driving MSNs to an 'up' or 'down state' .....	165

*Abbreviations:* CAR, conditioned avoidance response; CS, conditioned stimulus; GP, globus pallidus; GPe, external segment of the globus pallidus; GPi, internal segment of the globus pallidus; LTD, long-term depression; LTP, long-term potentiation; MSNs, medium spiny neurons; NAC, nucleus accumbens; SNc, substantia nigra pars compacta; SNr, substantia nigra pars reticulata; S-R, stimulus-response; STN, subthalamic nucleus; TANS, called tonically active neurons; US, unconditioned stimulus.

\* Corresponding author. Tel.: +55 41 3361 1717; fax: +55 41 3266 2042.

E-mail address: [dacunha@pq.cnpq.br](mailto:dacunha@pq.cnpq.br) (C. Da Cunha).

3.4.2.	Go/NoGo units .....	165
3.5.	Gathering action units .....	165
4.	Emergent properties of the 'mosaic of broken mirrors' model .....	165
5.	Conclusion .....	166
	Acknowledgements .....	167
	References .....	167

## 1. Introduction

At the first half of the last century, Parkinson's and Huntington's diseases were known by their motor disabilities. The discovery that these diseases are caused by the degeneration of components of the basal ganglia led to the theory that this system is exclusively involved in motor functions [13,55,164]. Over the last decades a growing body of evidence has shown that Parkinson's and Huntington's disease patients also present marked cognitive disabilities [78,112,127,142,155]. It also became evident that the malfunctioning of components of the basal ganglia contributes to cognitive disabilities in mental diseases such as schizophrenia [93], attention-deficit/hyperactivity disorder [24], and addiction [11,58].

The involvement of the basal ganglia in cognitive processes also became evident from studies on learning and memory carried out after the second half of the last century. Studies involving patients who became amnesic after lesion to the medial temporal lobe (such as patient H.M.) have shown that these patients conserved some learning and memory abilities later named nondeclarative or procedural memories [190,196]. These clinical studies, complemented by investigations on animals with experimental brain lesions (i.e., the hippocampal formation and the dorsal striatum), supported the theory of multiple memory systems in the brain ([136,137,157,159–162], see also Refs. [196,214] for a review). In this context, the hippocampus and the adjacent cortex of the medial temporal lobe were considered to be components of the declarative memory system and the striatum was considered to be a critical component of the nondeclarative or procedural memory system.

Nowadays there are many theories to explain the role of the basal ganglia in cognitive and motor functions. One view accepted by many researchers is that the basal ganglia form a system selecting actions appropriate under specific circumstances [6,30,64,83,102,108,114,135,174,191]. In this context, procedural memories are products of basal ganglia processing. Motor skills [51,52,95,189], Pavlovian conditioning [10,187], action-outcome instrumental conditioning [7,143,173,217,222], and habits [7,136,214,222] are examples of procedural memories processed by the basal ganglia.

What kind of computation do the basal ganglia do that result in these types of procedural memory? The term procedural memory means knowing "how to do something" rather than "what to do", which is a kind of knowledge encoded as a declarative memory. As suggested by some authors, the expression of procedural memories is the product of an action selection process [6,83,135,149,174] based on associations, i.e., sequential associations of a chain of movements in skill learning; association of an action-eliciting stimulus with a neutral stimulus in Pavlovian conditioning; association of a discrete stimulus with the outcome of a specific action in instrumental conditioning. In all of these cases, the choice of the most adaptive association in a given situation is learned in a reinforcement-driven gradual process [53,158,214].

The present paper proposes a unified model to explain how the basal ganglia process learning and memories. This model, here named the 'mosaic of broken mirrors', is based on the known circuit and properties of the basal ganglia, most of them reviewed in

this special issue of *Behavioural Brain Research*. It explains how the associative process occurs in the basal ganglia and how the choice of the most adaptive associations increases as a function of the novelty and salience of a stimulus and the outcome of the action associated with it.

## 2. The basal ganglia circuitry

A detailed review of the anatomy, physiology, and biochemistry of the basal ganglia is beyond the scope of this article and can be found elsewhere [15,48,163]. The description that follows is a concise view of the basal ganglia components and properties sufficient for readers to understand the model proposed in the article to explain the basal ganglia processing of learning and memory.

The core components of the basal ganglia are the dorsal and ventral striatum and the globus pallidus (GP). The dorsal striatum is formed by the caudate nucleus and the putamen. Many authors refer to the ventral striatum as the nucleus accumbens (NAc), its main part. The GP consists of an internal (GPi) and an external (GPe) segment and of the ventral pallidum. Due to their reciprocal connections with these core structures, the substantia nigra, ventral tegmental area, and subthalamic nucleus (STN) are considered to be associated basal ganglia structures. The substantia nigra comprises two parts: the substantia nigra pars compacta (SNc), and the substantia nigra pars reticulata (SNr) parts [163].

The basal ganglia nuclei form partially closed loops with the neocortex and thalamus (Fig. 1). Neurons from most parts of the neocortex project to the striatum [48]. Sensorimotor subthalamic structures also project directly to the striatum or by innervating other thalamic regions that project to the striatum [131]. Striatal neurons project to the GP or to the SNr which projects to specific thalamic nuclei that, in turn, project back to the frontal cortex. Projection neurons of the neocortex, STN, and thalamus are excitatory (glutamatergic), whereas projection neurons of the striatum, GP, and SNr are inhibitory (GABAergic). Therefore, the activity of different regions of the neocortex affects the activity of the basal ganglia that, in turn, modulate motor and cognitive parts of the frontal cortex. The positive modulation exerted by thalamic neurons in the frontal cortex is under inhibitory control of the GPi and SNr. This inhibition can be either blocked by a direct pathway or can be increased by an indirect pathway of neurons that arise in the striatum. The direct pathway is a projection of the striatum to the GPi/SNr. The indirect pathway is formed by striatal neurons that project to the STN which, in turn, projects to the GPe. The latter then sends projections to the GPi/SNr. Both the GPe and the STN present reciprocal projections to many nuclei of this circuit, thus working as relay stations. Midbrain dopaminergic neurons project mainly to the striatum. Dopamine released by these neurons activates the direct pathway and inhibits the indirect pathway by acting on 'D1-like' (D1 and D5) or on 'D2-like' (D2, D3, and D4) dopamine receptors, respectively. Both actions result in a positive modulation of the motor and cognitive functions of the frontal cortex [2,30,48,163]. The segregation of the direct and indirect pathways seems to be

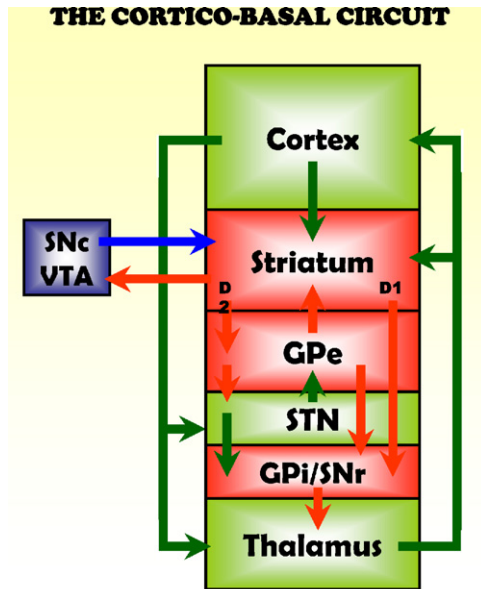

**Fig. 1.** An updated and simplified diagram of the Alexander et al. [2] cortico-basal ganglia network. Glutamatergic synapses are indicated by green arrows, GABAergic synapses by red arrows and dopaminergic synapses by blue arrows. Abbreviations: D, dopamine receptors; GPe, external globus pallidus; GPi, internal globus pallidus; SNc, substantia nigra pars compacta; SNr, substantia nigra pars reticulata; STN, subthalamic nucleus; VTA, ventral tegmental area.

incomplete, with many projection neurons of the striatum expressing both D1 and D2 receptors [199]. In these cases, one family of dopamine receptors may predominate in each subpopulation of neurons.

Almost 95% of the neurons of the striatum consist of GABAergic projection neurons called medium spiny neurons (MSNs). The other striatal neurons are interneurons that interact and modulate the activity of MSNs, including parvalbumin-containing, GABA-releasing interneurons; NADPH diaphorase- and somatostatin-positive interneurons, and giant cholinergic aspiny interneurons, also called tonically active neurons (TANs) [107,166,201].

The homogeneity of the cytoarchitecture of the striatum is only apparent. The MSNs of the direct and indirect pathways are homogeneously mixed [71,72]. However, the MSNs form patches of acetylcholinesterase-poor but  $\mu$  opioid receptor-rich regions, named striosomes. Striosomes are surrounded by a dense acetylcholinesterase-rich matrix [81].

The striatum is the input unit of the basal ganglia. Practically all modalities of cortical regions project to the striatum. Elegant studies conducted by [62,63] regarding the projections of the primary somatosensory and motor cortices of monkeys to the striatum have revealed that units of different modalities of somatosensory and motor information, encoded in different areas of the cortex, project to the same area of the striatal matrix. The authors called each region of the matrix representing a part of the body a *matrisome*. The cortical regions encoding, for example, the motor and sensory (pain, temperature, and pressure sensitivity) properties of a finger of a monkey overlap in the same *matrisome*. More intriguing, the authors found several *matrisomes* in the striatum encoding for the same functional part of the body. This indicates that a regions in the cortex that represent a body part project to several *matrisomes* in the striatum. In this respect, the distribution of *matrisomes* in the striatum is a mosaic of multiple sensorimotor units that are repeatedly represented.

The concept of corticostriatal convergence and disperse repetition of *matrisomes* in the striatum is in contrast to the concept of segregated and parallel corticostriatal circuits. There is a current debate about which of these concepts better explains corticostriatal functioning [22,72]. Many studies have shown convergent and overlapping corticostriatal projections, including regions beyond the somatosensory areas such as the prefrontal [22,87,192], posterior parietal [28,175], secondary visual [28,175], and cingulate cortex [224], among others [123,150,179,221].

Zheng and Wilson [224] showed that the axonal arborizations of corticostriatal neurons form a pattern of multiple focal and dense innervations dispersed within a vast area of the striatum, similar to the *matrisomes*. The same pattern of multiple focal cortical projections with widespread terminal fields in the striatum have also been reported by other investigators [22,72]. In addition to these patchy corticostriatal projections, these authors also found diffuse projections that would “broadcast” the cortical activity to different areas of the striatum, thus increasing the probability of corticostriatal convergence.

However, corticostriatal convergence may not be complete and is certainly not homogeneous throughout the striatum. Areas of predominantly (but not absolutely segregated) sensorimotor, associative or limbic cortical projections in the striatum exist, as proposed by the parallel segregated loops model [2] and in agreement with experimental evidence [105,177].

### 3. The ‘mosaic of broken mirrors’ model

The model is inspired by the properties of the cortico-basal circuitry described above. It proposes that the striatum processes cortical information in an operation similar to the generation of images of a person and his environment in a mirror house. The images are repeatedly represented in the many mirrors. The mirrors are broken into many pieces that conserve fragments of the image. The repetition of the multiple pieces facilitates their combination into a mosaic. The mosaic is the product of a particular combination.

#### 3.1. Breaking the mirrors: functional convergence and widespread repetition

The first postulate of this model is based on the generalization of the finding that corticostriatal projections from the somatosensory and motor cortex form *matrisomes* in the striatum [62,63]. According to this postulate, all cortical projections to the striatum are functionally convergent and form ‘*matrisome-like*’ units widely dispersed within the striatum (see Figs. 3 and 4). The term *matrisome* was proposed by Flaherty and Graybiel because they found out that all corticostriatal projections from the somatosensory and motor cortices made synapses with MSNs of the matrix and not of the striosomes [62,63]. However, more recent studies have reported focal projections from other cortical regions forming ‘*matrisome-like*’ terminals in both the matrix and the striosomal compartments of the striatum [224]. Thus, these “*matrisome-like*” units will be named here ‘functional units’ of the striatum.

#### 3.2. Building functional units

##### 3.2.1. Body parts

The first question is what do these ‘functional units’ represent? Let us go back to the ‘functional units’ called *matrisomes* by Flaherty and Graybiel [62,63]. The *matrisomes* integrate different sensory and motor properties of articulated parts of the animal’s body, i.e., a functional part with motion properties. The model proposes that functional units allow the striatum to program actions based on the

movement of articulated parts of the body in relation to each other and to the environment.

### 3.2.2. Objects

What about the representation of sensory information of the surrounding world in the striatum? We propose that they are also encoded in the pieces of the 'broken mirrors'. Each piece individualizes an object with which a part, or the whole body, can interact. Each object is repeatedly encoded in many striatal units. These units are the same that also represent each body part in a repeated and random way. Therefore, when an object appears in the receptive field of a unit representing a body part, the firing of its neurons will increase. In other words, the firing of the neurons of a unit representing a body part increases when an object is close enough to that body part (see Fig. 2). Touching the left eye with the right index finger, kicking a ball, eating an apple, sitting on a chair, are examples of such actions. Therefore, we propose that, due to the repetition of the units representing the same objects and body parts, the increased excitation of a unit representing an object can move through the units representing different body parts as illustrated in Fig. 2. We also propose that objects are encoded in the striatum in a multi-sensory way. That means that the units encoding the body part that is approaching an object will respond to the view, touch, smell, or sound of that object.

Many known characteristics of the cortical projections to the striatum are coherent with our model. The ventral stream of visual information concerning object cognition is directed into the area TE, located in the inferior temporal cortex [212]. In primates, TE projects to the tail of the caudate nucleus and caudal/ventral

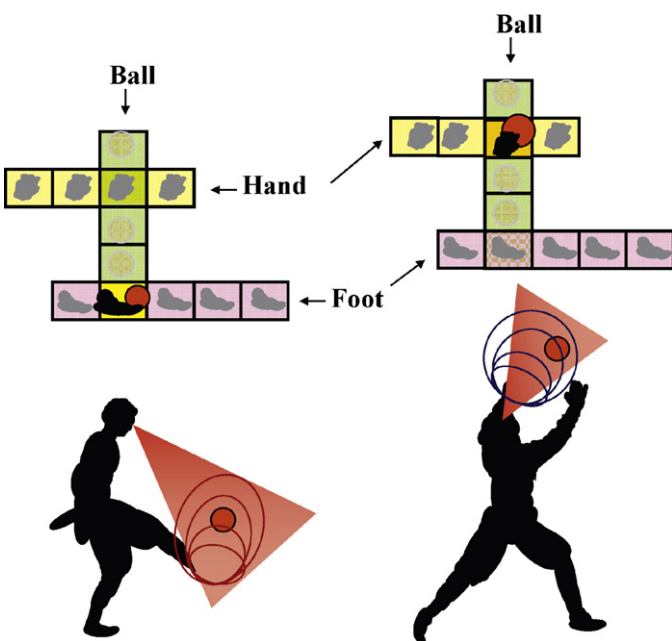

**Fig. 2.** These diagrams illustrate how the striatum encodes actions of a body part towards an object, according to the 'mosaic of the broken mirrors' model. Functional units of the striatum are represented by interlinked squares. They encode body parts that can interact with objects of the nearby environment. These objects are also represented by these units in a repeated way. The representation of an object and a body part can overlap in the same unit. Overlapping representation of a specific body part with an object seen, heard or smelled occurs by chance, due to the widespread distribution of these units. Each unit encodes an object in body part-coordinates, i.e., in coordinates centered in the body part that it also represents. Polymodal neurons of these units, like a hand-vision neuron, respond to an object only when it is seen near the hand. In the left sketch, a striatal foot-unit is activated to release a movement of the foot towards a ball seen close to it. In the right sketch, a striatal hand-unit is activated to release a movement towards a ball that approaches that hand.

portions of the putamen in a patchy manner [88,212]. The striatum, in turn, projects back to TE via SNr/thalamus [134]. This remarkable exception of the rule that basal ganglia output is exclusively directed at the frontal cortex, stress how important representing objects in the striatum is. The striatal neurons receiving these patchy projections from TE are intermixed by striatal neurons with receptive fields of one or more sensory modalities: visual [18,31,33,60,82,88,89,96,104,130,146,148,150,167,176], somatosensory [62,96,148], auditory [29,148,184], gustatory [67], and olfactory [193]. Inputs from sensory neurons of other higher visual cortical areas, extra-geniculate sensory thalamus, and the superior colliculus are also likely to contribute to the sensory and movement properties of the objects represented in the striatum [148]. In agreement with the view that the striatum encodes body parts and objects, visual and somatosensory modalities predominate among striatal neurons [82,148] and many of them are selective to approaching stimuli [82,150,194]. Except for the patchy projections from TE [88], these neurons present large size receptive fields and no signs of retinotopic or continuous somatotopic organization ([147], but see Refs. [36,82]). Their receptive fields cover the whole visual field, auditory perimeter, and body surface [148].

The striatum is widely regarded as being involved in sensorimotor integration [9,48,163,121,214,222]. According to our model this integration can be achieved if the locations of an object are encoded in the striatum, not in the retinotopic-, but in body part-coordinates. In other words, we propose that the striatal neurons located in the unit representing a hand will respond to the vision of an object only when it is near to that hand (see Fig. 2). This model predicts that the closer the hand is to the object, the higher the firing rate of the visual neurons of that unit will be. It is exactly the picture found by Graziano and Gross [82] while recording from the ventral putamen of anesthetized monkeys. They reported that some neurons presented a tactile receptive field covering the whole body and visual fields restricted to a visual angle. Others, responsive to the touch of a cotton swab in the monkey's face while its eyes were covered, increased their firing after the animal had its eyes uncovered so that it could see this object approaching its face. The same neuron did not respond before the object was 10 cm or less from the animal's face. They defined the visual receptive field of this neuron as "corresponding to the solid angle centered at the tactile receptive field and extending out approximately 10 cm" [82]. They reported receptive fields centered in other body parts extending from some centimeters (e.g., a hand) to more than a meter away out to the wall of the room (e.g., an arm). Coherent with the hypothesis that these striatal neurons encode objects that can be manipulated by a body part, when the arm of the animal was moved out of its vision, a typical "arm + vision neuron" no longer responded to the presence of the object to its field of view. Based in these findings they propose that the striatum encodes objects located in the visual space surrounding the subject in body part, rather than in retinotopic coordinates. Our model not only incorporates this theory, but also proposes a mechanism by which this body part-centered coordinates may arise in the striatum (see Fig. 2).

Such model also explains why the dysfunctions of the basal ganglia (and their loop with TE) lead to alterations in visual perception, like visual hallucinations [134], impaired reaction times in visual search [116], and impaired pattern/object location associative learning [60,116,134].

### 3.2.3. Locations

While the actions towards objects located in the space immediately surrounding the subject demand body part-centered coordinates, actions toward distal targets demand spatial coordinates. No consensus exists that the spatial context is represented in the striatum [49,128,139,141,214,222]. Behavioural studies report-

ing a double dissociation between the dorsolateral striatum and the hippocampus for spatial and stimulus-response (S-R) learning tasks have initially led to the view that the striatum is not important for spatial tasks. These studies included spatial and cued versions of the Morris water maze [156,159], radial maze [159], and plus-maze tasks [160]. Other studies from our group have also shown this dissociation between the SNc and the hippocampus [38,40,42,43,61,138].

However, even the cued tasks mentioned above require some degree of spatial information to be solved. In those studies, the cue (i.e., a ball, a salient platform, a light) can be conceived as an object which the animal needs to approach in order to be rewarded. Since this object is located in a specific place of the maze, the behaviour of the rat can be conceived as “to go to that object located in that place”. In some instances, such as in a plus-maze or T-maze, the reference is not an object but a hemi-side of the animal’s body (egocentric orientation) which permits encoding behaviours such as making a right or left turn to be rewarded [16,106]. Even in these cases, the task involves performing an action (turn) in a specific place.

Evidence that the striatum encodes spatial information about the environment came from studies reporting that, like the hippocampus [153], the striatum also contains place-related cells, neurons that discharge when the animal is in a particular place of the environment [57,139–141,172,213]. Compared to the hippocampal place cells, those found in the striatum are more influenced by other parameters of the task [111]: they also encode egocentric movements and are more sensitive to visual cues [141] and reward variables [111,126,140,141,194]. The striatum, as well as the hippocampus, also contains a subpopulation of neurons called head direction cells that fire preferentially when the animal’s head is aligned with a particular orientation, irrespective of the animal’s location [139,141]. These neurons are probably involved in egocentric movement.

The difference between the tasks depending on the dorsal striatum and those depending on the hippocampus is that, in the former, the location of the target does not need to be defined in terms of multiple relations between distal cues. In a recent study, we have shown that inactivation or lesion of the striatum or of the SNc does not impair the ability of rats to navigate in a water maze when they always depart from the same starting point to find a hidden platform kept in the same place in the maze ([40], see Ref. [159]). The animals learn this task probably by using a single object of the environment as a distal cue. Animals with intact striatum and a lesion in the hippocampus may orient themselves in an environment, but this orientation is not sufficient to disambiguate places equidistant to the same environmental object. This dissociation has been shown by McDonald and White [128] in rats searching for food in two adjacent arms of an 8-arm radial maze. Rats with a hippocampal disconnection, but with an intact striatum, were unable to solve this task. However, the same rats were not impaired to discriminate in which of the two arms, separated by other two or more arms, they would find the food. In the latter case the animals probably use different distal cues to discriminate between arms.

According to the ‘mosaic of broken mirrors’ model, the representation of space in the striatum may account for the characteristics of the tasks that can be learned with the participation of the striatum. This model postulates that cortical projections to the striatum are fragmented into pieces, with each piece representing a location. In other words, this model assumes that, while the hippocampus represents space as a continuum, the place fields in the striatum are repeated and intermixed. This configuration facilitates the association of objects (cues) with particular places, but breaks the orthogonal relationships among different locations. Therefore, the hippocampus is in a position to compare the current spatial context

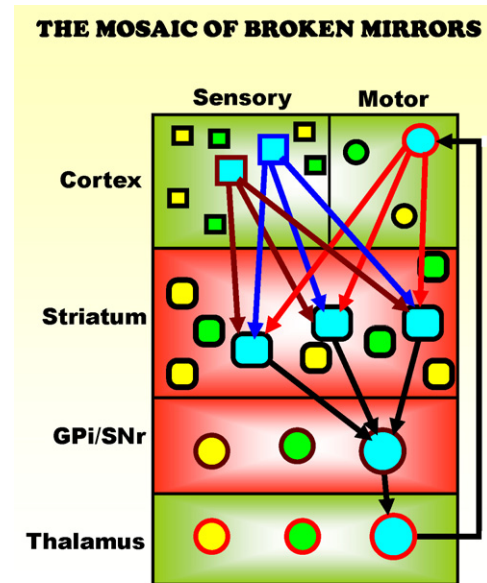

**Fig. 3.** This diagram illustrates the redundancy and functional convergence properties that the ‘mosaic of broken mirrors’ model proposes to the functional units of the striatum. The indirect pathway and the dopaminergic modulation are not represented in order to simplify the diagram. Abbreviations: GPi, internal globus pallidus; SNr, substantia nigra pars reticulata.

of the environment with the context found in the past. On the other hand, the striatum is in a position to choose an action that can move the “pieces of the mosaic (the subject’s body, body’s parts, objects) to a particular location. According to this view, the hippocampal representation of the environment is globally oriented, while the striatal actions depend on breaking the environment into pieces in order to move them. Hence, tasks such as the cued version of the water maze or the win-stay version of the radial maze can be easily solved by the striatum by associating the approaching action with the place in which an object (cue) is located.

The action of approaching a location cannot be encoded in the hippocampus since it does not have direct connections with motor areas of the neocortex. This location–approaching action association is probably done in the striatum that receives direct inputs from the hippocampal formation to the shell region of the NAc, and indirect inputs to the core of the NAc through the prefrontal cortex and to the ventromedial striatum through the medial entorhinal cortex [66,119,129,202].

We recently obtained some curious results in experiments of latent learning that can be explained by the assumption of the ‘mosaic of broken mirrors’ model that the striatum represents space in a fragmented way. We found that the impairment of SNc-lesioned rats to perform the cued version of the water maze disappeared when the animals were pre-trained in the spatial version of this task [42]. Curiously, SNc-lesioned rats were not impaired to perform the spatial version. A series of control experiments showed that the presence of the hidden platform and the view of the distal cues during the pre-training sessions were critical for that beneficial effect. More intriguing was the finding that this improvement was observed even when the locations of the distal cues (posters fixed on a curtain around the maze) were changed in relation to the pre-training session. Our model explains these data by assuming that the spatial map formed during the pre-training sessions was broken into pieces, each containing a distal cue. Hence, a particular cue could be associated with the action of approaching it, irrespective of its relationship with the other cues.



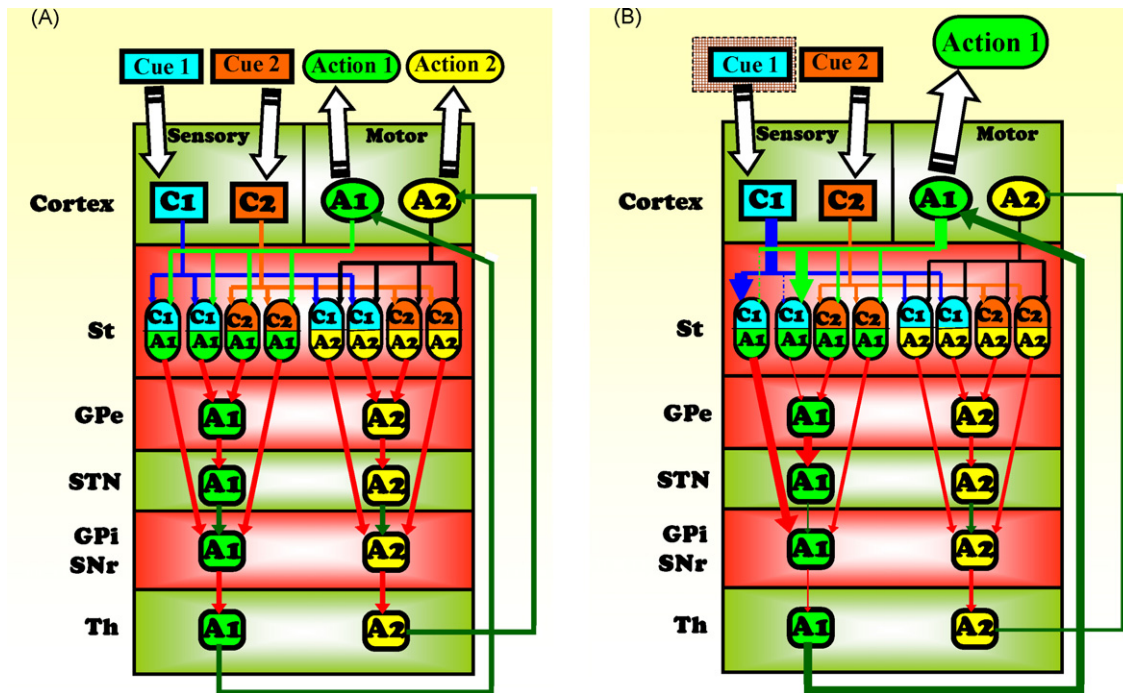

**Fig. 4.** This diagram demonstrates the combinatorial, associative, learning, and action selection properties of the mosaic of broken mirrors model. Neurons are represented by boxes and circles. The colours of the arrows linking glutamatergic cortical neurons to striatal neurons denote their origins. Arrows linking the other components of the basal ganglia circuit represent axons of GABAergic (red) or glutamatergic (green) neurons. (A) Before learning occurs, the circuit allows the association of any environmental cue with any action. (B) After pairings of the salient Cue 1 with Action 1, coincident with a phasic release of dopamine (not shown), the following alterations occur, restricted to the synapses between cortical neurons representing Cue 1 and those representing Action 1 that converge to the same striatal neurons: LTP in the direct pathway for Cue 1; LTD in the indirect pathway for Cue 1; LTP in the indirect pathway for Action 1; LTD in the direct pathway for Action 1. Alterations in the synapses of Cue 1 increase the probability that it will induce the choice of Action 1. The alterations in the synapses of Action 1 lead to the conclusion of the action. Abbreviations: GPe, external globus pallidus; GPi, internal globus pallidus; SNr, substantia nigra pars reticulata; St, striatum; STN, subthalamic nucleus; Th, thalamus.

In another study carried out in our laboratory, we found further evidence that units of the striatum encode actions directed at a goal (unpublished results). In that study, rats with complete hemileSION of the SNc induced by 6-hydroxydopamine were trained to enter the lighted arm of a radial maze in order to find a sucrose pellet. The lesion prevented the animals from running directly to the lighted arm when it was located on the side contralateral to the lesion. However, these animals made ipsiversive turns in order to adjust their pathway and enter the lighted arm. This result suggests that the action of approaching a goal, but not the goal *per se*, depends on the release of dopamine in the striatum contralateral to the goal location. Although SNc-hemileSIONed rats have lost the basal ganglia modulation that helps them to choose making contraversive turns, they could still approach a goal located on their contralateral side by means of other actions (i.e., ipsiversive turns). When the dopaminergic receptors of the hemileSIONed striatum were stimulated by the administration of a dopamine receptor agonist (i.e., apomorphine), these animals did not only recover their ability to perform contraversive turns, but also overrid this action due to supersensitization of D2 dopamine receptors [41]. These results are in agreement with the postulate of the “mosaic of broken mirrors” model that the activation of specific actions (such as turns) directed at a goal is encoded by the functional units of the striatum. Other actions involved in the practice of innate behaviours, such as grooming [34] and predatory hunting [183], have also been reported to depend on the striatum.

Therefore, the model proposes that not only the hippocampus, but also the striatum, is needed to solve spatial versions of water and radial mazes. The poor performance of striatum-lesioned rats in these tasks has been attributed to lesions more restricted to the dorsolateral striatum, sparing other regions that receive direct or

indirect projections from the hippocampus, i.e., the dorsomedial striatum [49,141,222]. According to this view, spatial navigation depends on both the hippocampus and the striatum. The hippocampus provides the map and the striatum the pathway to navigate through it. Coherent with this postulate, neurons encoding for particular behaviours such as turns have been found in the striatum, but not in the hippocampus [141]. Mulder et al. [145] reported the existence in the striatum of “goal”-like neurons that fire continuously while a rat moves from one location to another in a plus-maze. These neurons may encode the paces of movements between landmarks of a route made up by pieces of the spatial map.

### 3.2.4. Other functional units of the striatum

The inputs to the striatum are not restricted to sensory, spatial or motor areas of the cortex. Prefrontal and limbic areas of the cortex also project to the striatum in a convergent and widespread manner. Convergence refers to afferents departing from different regions of the cortex to overlap in restricted areas of the cortex forming ‘matrisome-like’ functional units. These units are widely distributed in vast regions of the striatum. What is the functional nature of these units? They may refer to affective meaning and to abstract information such as symbols, words, digits, thoughts, and plans. The processing of these functional units by the basal ganglia would explain the involvement of the latter in working memory and executive and affective functions [26,132,154].

### 3.3. Building associative units

Once objects, locations, body parts, symbols, and associated actions or plans are individualized into functional units in the striatum, what is the function of their repeated representation?

The answer is associative learning. The body, the surrounding world and the mental world can be combined into more flexible associations if they are broken into pieces (see Fig. 3). Repetition increases the probability of association among pieces and explains the involvement of the basal ganglia in different kinds of associative learning: Pavlovian conditioning for the association between a conditioned stimulus (CS) (a neutral stimulus) and an unconditioned stimulus (US) (a rewarding or aversive outcome) [10,187]; instrumental or operant conditioning for the association of a predictive cue with an action outcome (reinforcement or punishment) [143,173,217]; addiction for the association between a drug with strong rewarding properties and its compulsive consumption [11,58]; skill learning for the association of a sequence of motor actions [1,51,52,95,189]. The associative property of basal ganglia proposed by this model also permits the striatum to play a role in action selection based on reinforcement of previous cue-action associations [6,7,30,64,114,191]. The ingredients for these associations are the synapses between the corticostriatal neurons and the MSNs encoding the functional units of the striatum.

### 3.3.1. Synaptic plasticity in the striatum

What are the mechanisms underlying the association of functional units of the striatum? The most likely candidates are the synaptic plasticity phenomena known to occur in the striatum. Both long-term potentiation (LTP) and long-term depression (LTD) have been reported to occur in synapses between the corticostriatal neurons and MSNs [20,50,218]. According to Hebb's rule, LTP occurs when presynaptic and postsynaptic neurons are depolarized at the same time. LTP can be induced in the striatum by repeated activation of cortical terminals [27]. Therefore, corticostriatal synapses are the binding elements associating information arriving from different regions of the cortex. This association may occur when LTP is induced in the synapses of the two corticostriatal neurons with the same MSN and requires a triple coincidence: the two cortical neurons and the MSN must be depolarized at the same time. Such coincidence fulfil the needs for the induction of heterosynaptic associative LTP [124]. The partially closed loops between the striatum–GPI–thalamus–striatum and the striatum–GPI–thalamus–cortex–striatum (Fig. 1) may result in reverberant activation of MSNs, a factor contributing to keep these neurons depolarized. Other loops involving the GPe and/or the STN may also play a role in such reverberation and/or in the modulation of this circuit. High-frequency firing of the corticostriatal neurons may also induce LTD in their synapses with MSNs ([19,120,211], see also Refs. [50,218] for a review). The concentration of dopamine and how dopamine receptors are distributed among MSNs are critical factors to determine the induction of LTD or LTP, as will be discussed in the next section. LTP and LTD of synapses associating different cortical inputs with the same MSNs may build the memory trace of associative learning mediated by the basal ganglia (see Figs. 3 and 4).

### 3.3.2. Dopamine-dependent synaptic plasticity

The synaptic plasticity necessary for the occurrence of associative learning in the striatum requires a learning signal, a message that signals when and how learning occurs. This message seems to be the release of dopamine ([99,187], but see Ref. [218]). The activation of dopamine receptors in MSNs is necessary for the induction of LTP or LTD. D2-like and (maybe) D1-like dopamine receptors are required for the induction of LTD, but the activation of D2 receptors favours the induction of LTD over LTP in some instances ([21], see also Ref. [218] for a different view). Activation of DB1 cannabinoid and adenosine A2A receptors also seems to be involved in the induction of the striatal LTD [50,70,218]. On the other hand, LTP

requires the activation of D1 receptors [25] and is inhibited by the activation of D2 receptors [21].

D1 receptors occur mainly in MSNs of the direct pathway (those projecting to the GPi/SNr), whereas D2 receptors are mainly expressed in neurons of the indirect pathway (those projecting to the GPe) [71,72]. Therefore, in the presence of dopamine, LTP is more likely to occur in the direct pathway and LTD in the indirect pathway. The direct pathway positively modulates actions encoded by the frontal cortex, while the indirect pathway inhibits their occurrence (see Section 2 above). According to the 'mosaic of broken mirrors' model, in the presence of dopamine, the concomitant activation of corticostriatal neurons encoding, for example, an object and the action of approaching it, would induce LTP in their synapses with MSNs of the direct pathway and LTD in synapses with MSNs of the indirect pathway. This feature would increase the firing probability of MSNs encoding the association between the stimulus (object) and the action of approaching it [101].

The complete segregation of the direct and indirect pathways is currently a matter of debate [48,87,218]. Induction of LTD that requires the activation of D2 receptors occurs in most MSNs [19,50]. In addition, there is evidence for the co-expression of D1 and D2 receptors in a subpopulation of neurons [199]. In these neurons the induction of LTP or LTD depends on the level of dopamine and on the depolarization state of MSNs. D2 receptors present a higher affinity for dopamine than D1 receptors [103]. As a consequence, lower levels of dopamine favour the induction of LTD and higher levels favour the induction of LTP [25].

What happens when the act of approaching an object is reinforced? The corticostriatal neurons encoding the object and the action of approaching it are activated at the same time. As a consequence, LTP or LTD would occur in the connections of MSNs that receive overlapping projections from these active corticostriatal neurons, with the occurrence of LTP in MSNs of the direct pathway and LTD in those of the indirect pathway (see above). This feature would increase the firing probability of these MSNs and the consequent occurrence of the approaching action when the same object is seen by the subject in the future.

### 3.3.3. Novelty-driven reinforcement learning

Midbrain neurons release dopamine in the striatum in tonic or phasic patterns [68,75–77]. A small amount of dopamine is spontaneously and continuously released by these neurons in a tonic pattern, providing a baseline level of extrasynaptic dopamine required to run the motor programs already set up [75]. The phasic firing of dopaminergic neurons causes a transient and robust release of dopamine and serves as a learning signal, inducing neural plasticity in the striatum. Coherent with this theory, the phasic release of dopamine is critical for Pavlovian conditioning [10,187] instrumental learning [143], and other types of associative and reinforcement learning [114,185].

The influential studies by Schultz and other groups suggested that the phasic release of dopamine occurs in response to unpredicted rewarding stimuli [10,143,188], with the amount of dopamine released being proportional to the difference between expected and obtained reward [188]. This difference is called reward prediction error. More recently, this theory has been contested by the argument that the latency for a stimulus to induce the phasic release of dopamine is too short to permit the sensory processing necessary to evaluate the stimulus identity and reward value [173]. The fact that the unpredicted presentation of non-rewarding salient stimuli such as light flashes or tones elicits a phasic dopamine response also disagrees with the reward prediction error theory [99,100,118]. Habituation to a stimulus abolishes the phasic dopamine response [118,187]. The omission of an expected reward causes a brief cessation in the firing of midbrain

dopaminergic neurons at the time the stimulus was expected to occur [186]. Aversive or detrimental stimuli (usually those that cause pain) induce a pause in the firing of dopaminergic neurons for the duration of the event, followed by a rebound response [32,210]. Therefore, the phasic dopamine response seems to signal the presence of new biologically significant stimuli, with a positive response (increased release of dopamine) to non-harmful stimuli (neutral or rewarding) and a negative response to harmful stimuli [173].

As stressed above, striatal synaptic plasticity depends on the activation of dopamine receptors. Therefore, the phasic release of dopamine serves as a permissive signal for learning processes that occur in the striatum. The fragmentation of the sensory representation of the environmental world and functional parts of the body involved in actions permits the individualization of these elements and their repetition increases the combinatorial association among them. After repeated presentation of novel stimuli associated with actions, the continuous reinforcement of the associations between pairs of stimuli or stimulus-action units that always appear together causes them to be more strongly associated than the stimuli and actions that are associated only occasionally. According to the 'mosaic of broken mirrors' model, it is the principle of the associative learning that forms expectations based on current stimuli and actions (see also [114,149,207,219]). After learning, the occurrence of a salient stimulus can be predicted and it will no longer induce the phasic dopamine response. The memory for this association becomes stable.

According to this model, the association of an action with its outcome depends on their representation in the striatum at the same time as the concentration of dopamine in the synapses are high due to the phasic response. Otherwise, the synaptic plasticity to strengthen the synapses between overlapping corticostriatal neurons and MSNs would be lacking. The phasic dopamine response seems to appear too early and to be too short [65,84,99,188] to permit the association of a stimulus with an action and its rewarding outcome [173]. However, the clearance of dopamine released in the striatum, particularly in the NAc and medial regions of the striatum, takes longer compared to the dorsolateral striatum [151,198,216]. This fact would explain MSNs in the striatum responding to previous actions and their reward outcome [35,92,97,114,115]. The clearance of dopamine may range from a few hundreds of milliseconds in the dorsolateral striatum to several seconds in the NAc [151,198,216]. This difference can account for the higher involvement of the NAc in action–outcome reinforcement learning and of the dorsolateral striatum in S-R habits [149,222]. The fast clearance of dopamine in the dorsolateral striatum opens a time window too tight to include the reward outcome to the S-R association. This might be the reason for the slow learning rate of S-R habits and for the fact that these habits are relatively insensitive to reward devaluation. On the other hand, in the NAc the slow clearance of dopamine after a phasic response is probably long enough to associate the outcome (reward) with the action, a fast learning that fades more easily after reward withdrawal or devaluation.

This postulate is in line with imaging and electrophysiological studies showing increased activity in the striatum in response to a reward [47,91,113,114] and reward prediction errors [90,152]. It is also supported by studies reporting that the lesion or manipulation of the rat SNc or striatum disrupts associative reinforced learning in various tasks such as the cued version of the Morris water maze [42,43,61,138], two-way active avoidance task [39,73,74,110], inhibitory avoidance [23,46,133,165,170,171,181], Pavlovian conditioning [168], and cued instrumental tasks [12,59,168,169]. Similar associative reinforced and habit learning deficits have also been observed in mouse and monkey models of Parkinson's disease, as well as in Parkinson's disease patients [60,78,109,112,178,182,200].

### 3.3.4. Aversively motivated learning

Associative learning mediated by appetitive reinforcement can be easily explained by the postulates of the 'mosaic of the broken mirrors' model since a short latency phasic dopamine response follows the reward presentation [186], as mentioned above. However, aversively motivated associative learning demands further elaboration since, as also mentioned above, aversive stimuli may induce a pause in the firing of midbrain dopaminergic neurons for the duration of the event, followed by a rebound response [101,210]. How can a reduction in the extracellular dopamine levels in the striatum induce learning, a process that demands neuronal plasticity? Let us discuss two popular models of aversively motivated learning: the active and the inhibitory avoidance tasks.

Learning the two-way active avoidance task, a kind of conditioned avoidance response (CAR), demands from a rodent to actively run away from a footshock (unconditioned stimulus) signalled by a cue (usually a tone or the light of the chamber, i.e., the conditioned stimulus) [39]. Training is carried out by the pairing of the CS and US in a two-chamber shuttle box. The CS starts before and turns off together with the US. After many consecutive pairings, the animal learns to avoid the US by crossing to the opposite chamber just after the presentation of the CS. Electrophysiological studies reported that most, if not all [210], midbrain dopamine neurons respond to noxious stimuli with a short latency increase in the firing rate, followed by a rebound offset ([32,69,98,122,173,208,210], but see Ref. [125]). The temporal resolution of microdialysis studies is not enough to detect the decrease in dopamine release in the striatum after a footshock, but these studies consistently detect the increase that may result from the rebound response that follows the ending of the noxious stimulus [100,205,223].

Thus, the increase in the extracellular concentration of dopamine probably coincide with the presentation of the "crossing" action that turns the US and CS off. The higher level of dopamine favours the induction of LTP between the corticostriatal neurons encoding the CS that converge to MSNs to which the corticostriatal neurons encoding the "crossing" action also project (see Section 3.3.2). This "crossing response" of the animal may be seen as the action of running away from the CS. Note that running away from a painful stimulus (US) is an innate behaviour, independent of learning.

Inhibitory avoidance, also called passive avoidance, demands that the animal (usually a rodent) avoids entering a particular place. Inhibitory avoidance training may be performed in the same two-chamber box used for two-way active avoidance conditioning [3]. The animal is placed in a lit chamber and receives a brief footshock when it enters the dark chamber. Usually only one session is needed for the animal to learn to inhibit the innate tendency of entering the dark chamber. In other words, it learns not to go to that location. The novelty of exploring the lit chamber probably induces a phasic response of the midbrain dopaminergic neurons ([117,118], but see Ref. [44]). The footshock probably induces the cessation of their firing [32,173,187]. Therefore, the act of remaining in the lit chamber will coincide with higher levels of extracellular striatal dopamine and the act of entering the dark chamber with the lowering in the level of dopamine. The former situation favours the induction of LTP between the corticostriatal neurons encoding the location of the lit chamber and MSNs receiving projections of corticostriatal neurons encoding the action of remaining there (see Section 3.3.2).

Therefore, we propose that in aversively motivated learning, it is not the reduction of the firing of midbrain dopamine neurons that induces learning, but the increase in the release of dopamine in the striatum before and after the aversive stimulus. In both active and inhibitory avoidances, the action that coincides with higher levels of dopamine is associated with the concomitant cue or location.

This hypothesis is coherent with the findings that manipulations in the SNc [39,73,74] or in the striatum [23,46,110,133,165,170,171,181] impair learning of these tasks.

Note that inhibitory avoidance may be learned as the association of an action with a place. However, such association would impair learning of the two-way active avoidance task in which the animal must successively return to the place in which it was punished. In this situation, the hippocampus, that encodes an environment as a place [153], is expected to play a detrimental influence. This prediction is in agreement with studies reporting that the lesion of the septum [180,206] or fimbria-fornix [85] improves learning of the inhibitory avoidance task. This illustrates a case in which the striatum and the hippocampus play competitive roles on learning [214]. It is coherent with the present view that the striatum encodes discrete stimuli and locations (see Section 3.2.3). The representation of both discrete cues and locations in the striatum does not mean that they will be always associated with the current actions. Only the activation of the striatal units that coincide with an action performed under high levels of striatal dopamine will be associated to this action. During learning of the two-way active avoidance, the act of running to a specific location (chamber) will be coincident with the release of dopamine only in 50% of the trials. On the other hand, the action of running from the CS will be reinforced by the release of dopamine in all occasions. As a consequence, the competition between the associations of the CS-“running from it” and the location-“avoid running to it” will be won by the former as trials go on. Such learning may be faster if the influence of the hippocampus is inhibited.

### 3.4. Building action units

#### 3.4.1. Driving MSNs to an ‘up’ or ‘down state’

The membrane potential of MSNs oscillates between ‘up’ (sub-threshold depolarized) and ‘down’ (hyperpolarized) states [220]. LTP is more likely to occur during the former and LTD during the latter state [20,50]. The higher activity of corticostriatal neurons representing actions and current features of the external or internal environment favours the ‘up state’ in MSNs to which they converge [197]. Since these functional units are represented in a repeated way [62,63,87], at least some of them probably overlap, thus presenting a higher probability to be in the ‘up state’ or depolarized. This probability is increased by the diffuse corticostriatal projections to a broader area of the striatum [22].

#### 3.4.2. Go/NoGo units

The result of striatal processing flows to the GPi and SNr, the output doors of the basal ganglia through the direct or indirect pathway (see Figs. 1 and 4). They build the ‘Go’ and ‘NoGo’ products of the basal ganglia processing [64] (see Figs. 3 and 4). The direct pathway is a GABAergic (inhibitory) connection between the striatum and GPi/SNr. The indirect pathway connects the striatum to the GPi by a sequence of neurons that finally exert an excitatory effect. Therefore, the direct pathway (Go) relieves the thalamocortical neurons from the tonic inhibition of the GPi/SNr. The indirect pathway (NoGo) results in the opposite effect [2] (see Section 2 above).

Since the ‘Go’ and ‘NoGo’ units affect almost exclusively the frontal cortex (through thalamocortical projections) and subcortical motor areas, they result in the induction/repression of actions, action planning, and other executive functions.

### 3.5. Gathering action units

The smaller number of neurons in the striatum, compared to the neocortex, imposes a convergence of the information originat-

ing from the neocortex to transform it into functional units [8,144]. In rats,  $17 \times 10^6$  corticostriatal neurons converge onto  $1.7 \times 10^6$  MSNs in the striatum [224]. The corticostriatal convergence is probably higher due to the repetition of the functional units (see Figs. 3 and 4).

The lateral inhibition among MSNs is seen as evidence for parallel and independent processing in the striatum [215]. However, other studies reported that this lateral inhibition is unilateral and restricted to less than one-third of the tested pairs [37,209], a finding favouring the proposal that the functional units of the striatum are formed by patches of MSNs receiving convergent and overlapping cortical projections. In this case, lateral inhibition may help isolate neighbouring functional units from one another. Since the functional units are repeated and widespread throughout the striatum, they may be distant enough to avoid lateral inhibition from their peers.

This repeated and widespread distribution of the functional units imposes a binding problem to coordinate the firing and plasticity between equal units. Recent studies suggest that this problem might be solved by a class of interneurons, presumed to be cholinergic, called TANs (see Section 2). These interneurons present a broad distribution, lying mainly at the borders of the striosome-matrix [4], and a low spontaneous firing rate that results in inhibitory effects on the excitability of MSNs [225]. TANs respond to rewarding events with a phasic decrease in their firing rate, at the same time that dopaminergic neurons increase their firing rate [5,14,79,143,195]. However, while in some instances the response of dopaminergic neurons seems to be proportional to the reward prediction error (see Section 3.3.2), the response of TANs is indifferent to reward predictability [143]. The dopamine response is timed to novel salient stimuli (including rewarding stimuli), but the time necessary to remove dopamine from the synapse is longer compared to the rapid removal of acetylcholine by dense acetylcholinesterase [225]. The sharp response of TANs to rewarding stimuli may result in a temporal synchronization of the repeated functional units formed by the patches of MSNs spread throughout the striatum. In other words, TANs may signal to MSNs when to learn, midbrain dopaminergic neurons may signal how to learn, and corticostriatal neurons may signal what to learn [143]. Coherently, the number of TANs responding to the reward signal increases in parallel with learning of Pavlovian [4] and instrumental [143] learning tasks. Learning probably results in a gradual recruitment of the numerous functional units of the striatum as learning progresses.

The projection of the striatum to the GPi and SNr imposes a second convergence of the order of  $10^2$ – $10^3$  [8] (see Figs. 3 and 4). This convergence probably accounts for the re-unification of the repeated functional units of the striatum [79], i.e., as learning progresses by recruiting a larger number of repeated units of the striatum, the activation of these convergent units of the GPi/SNr increases. Since the GPi/SNr projects almost exclusively to the frontal cortex (through the thalamus) and brainstem motor nuclei, they probably encode mainly actions and plans.

## 4. Emergent properties of the ‘mosaic of broken mirrors’ model

Most of the attributes of nondeclarative memories are emergent properties of the ‘mosaic of broken mirrors’ model. These memories are said to be implicit (unconscious) [196], rigid (inflexible) [56], procedural (expressing how to do something) [196], and suitable to guide cue-based and egocentric navigation [214]. The learning of most of these memories is a slow and gradual [54,158,222] associative process that depends on reinforcement [58,94,204], and sometimes forms habits after overtraining [136,222].

The implicit nature of memories that depend on basal ganglia processing is explained by the fragmentation of the information that occurs in the striatum, so that neither the subject's own body nor its environment are globally perceived during learning. Instead, few components of the environment are associated with discrete actions. This learning process is highly adaptive in order to adjust automatic responses (actions) to discrete changes in environmental elements. However, the meaning of this behaviour does not make sense in the global environment, simply because it is not globally oriented.

The rigid or inflexible aspects of these memories may be explained by this model for the same reasons. Since these memories are formed by associations of fragments of information about the environment and specific actions, their expression cannot be flexibly used in another context of the environment because of the lack of a global view of the environment. Even chains of actions performed in a skill are not oriented as an action of the subject in a complex environment, but as an automatic sequence of single actions.

Since the output of the basal ganglia is almost exclusively the frontal cortex and brainstem motor nuclei, the memories encoded by this system must be expressed as actions. This explains the procedural nature of these memories.

The fragmented representation of the environment in the striatum also explains the cue-based and egocentric navigation during basal ganglia-dependent learning. This type of navigation is not oriented towards a global view of the environment, but rather relies on discrete environmental cues or sequences of movements based on egocentric orientation [17,45,203]. The broken representation of the environment favours the association of units of information (cues) relevant as reward predictors with actions performed to approach the place in which the reward is delivered. However, this fragmentation does not allow multiple relations between environmental elements to form a spatial map. As a consequence, it stores information sufficient only to guide the navigation by steps based on sequential approaches to cues or sequences, for example, of right/left turns at specific locations.

One of the most evident properties of the 'mosaic of broken mirrors' model is that it is ideal to perform reinforcement associative learning. The repetition of the functional units formed in the striatum by convergent projections of the cortex amplifies the combinatorial power of the system. The dependence on dopamine to strengthen or weaken the associations among stimuli, actions and outcomes makes this associative process conditional. The release of dopamine only when the stimulus or the outcome are unpredictable (unlearned) becomes the driving force of learning mediated by this system.

The slow and gradual learning of procedural memories can be explained by two characteristics of this model. Reinforcement learning starts with trial and error associations, followed by evaluation of the outcome, and progresses by multiple comparisons between the reward prediction and/or the novelty of stimuli and the outcome during each trial. It is by definition a gradual process. The gradual recruitment of the functional units that are repeated in the striatum also contributes for learning to become slow and gradual.

Some types of instrumental learning result in a strong association between a stimulus and an action that becomes resistant to reward devaluation. This kind of associative memory, in which the stimulus becomes stronger than the outcome to trigger the response, is called habit [222]. The repetition of the functional units in the striatum mediating this association after extensive learning may partly account for this property. The more this associative memory becomes represented by a larger number of associative units, the more difficult it will be to erase them when the reward

outcome or the novelty decreases. In addition, the spreading of these associative units throughout the striatum increases the probability of their occupying striatal regions less sensitive to the reward outcome. Recent findings suggesting a gradient from the ventral to the dorsal striatum in the clearance of dopamine and regional differences in dopamine-dependent synaptic plasticity may account for these differences [216]. The formation of association units less sensitive to a reward is slower and so is their dissociation after reward withdrawal. If this is the case, the ventral striatum (NAc) would account for a fast and transient learning observed during the first trials of an instrumental task, while the dorsal striatum would account for the slow and strong (more resistant to reward devaluation or withdrawal) learning (habit) achieved after overtraining.

## 5. Conclusion

In figurative words, we propose that the cortico-basal processing of procedural memories is similar to a mosaic consisting of pieces of images of several broken mirrors. According to this model, neurons of the sensory, motor and associative cortices send convergent projections to the striatum that result in functional units (see Figs. 3 and 4). These striatal units encode articulated parts of the body and portions of the surrounding world that can be moved or manipulated, such as surrounding objects (Fig. 2). These units also encode specific locations to which the subject can move. The association of these functional units results in programs to perform motor skills and movements of the arms, eyes, or other body parts to a specific target (object or location), or in the locomotion of the subject to specific targets. The combinatorial power of these associations is amplified by the repeated and widespread distribution of the functional units in the striatum.

According to this model, learning in this system depends on the alteration in the strength of the synapses between the corticostriatal neurons and MSNs that encode the functional units (Fig. 4). It occurs when an environmental stimulus becomes salient in an unpredictable way. At this time, the midbrain dopaminergic neurons release dopamine in the striatum in a phasic pattern. The activation of dopaminergic neurons is a condition for the occurrence of synaptic plasticity in the striatum. The synchronization of neurons of the repeated functional units encoding the same action in relation to the salient stimulus is performed by a pause in the release of acetylcholine by TANs. The striatal units encoding the same stimulus/action send convergent projections to the GPi and SNr that, in turn, drive the encoded action to the frontal cortex (passing by the thalamus) (Fig. 3). The partially closed loops involving the GPe, STN, thalamus, and striatum may result in reverberation that facilitates the induction of LTP or LTD in the striatum. These loops may also have other modulatory functions in this system.

Still according to this model, the stronger association between the functional units of the striatum encoding an action triggered by a stimulus makes the occurrence of this association no longer unpredictable. As the novelty is reduced, the salience of the stimulus decreases and no further learning occurs. In this respect, this learning system is driven by novelty.

After a phasic dopamine response, the high concentration of dopamine takes longer to be cleared in the synapses of the NAc compared to the dorsal striatum [151,198,216]. In other words, the learning signal that allows synaptic plasticity lasts longer in the NAc than in the dorsal striatum. Accordingly, this learning signal is long enough to incorporate the evaluation of the reward value of the action outcome in the NAc, but not in the dorsal striatum. It explains why learning mediated by the NAc is driven by the reward outcome of the action, while learning mediated by the dorsal striatum forms S-R habits that are less sensitive to reward. This

model explains the gradual learning and many known properties of different types of procedural memories, such as allowing cue and egocentric navigation and their implicit, inflexible and associative nature.

Several postulates of the ‘mosaic of broken mirrors’ model need to be tested in future studies, particularly those that are the core of this model and differentiate it from other models of basal ganglia functioning: the postulation of the existence of repeated functional units in the striatum and their associative combination to form procedural memories. Nevertheless, these postulates are coherent with current findings, such as the “matrisomes” discovered by Flaherty and Graybiel [62,63], evidence for convergence and widespread projections from different regions of the cortex to the striatum [22,28,72,123,150,175,179,192,221,224], cue and egocentric navigation mediated by the basal ganglia [38,40,42,43,61,138,159], and place-related cells in the striatum that also encode movements [141], among other findings reported in this review. The remaining postulates of this model were mainly incorporated from existing models [2,8,64,80,86,144,158,173,214,216], except for the mechanism proposed to explain how the NAc and dorsal striatum encodes action-outcome expectancies and S-R habits, respectively.

A model can be considered as equivalent to a map of a new land based on the landmarks discovered by explorers that made blind navigations through it. This map results from the recreation of the cartographer that tries to accommodate the landmarks to his logic and imagination. This map is not an infallible orientation to new explorers, but it can provide routes to the exploration of this land. The explorers may confirm or not the locations in this land according to the map. Such is the case for the striatum according to the ‘mosaic of broken mirrors’ model; the map can be improved based on the outcome of these intents. We hope that the ‘mosaic of broken mirrors’ model may be of some help to guide the work of researchers interested in understanding how the basal ganglia mediate procedural learning.

## Acknowledgements

The editorial comments of Rainer K.W. Schwarting, Philip Winn, Jorge Medina, and Ivan Izquierdo are acknowledged. This work was supported by grants of Institutos do Milenio (CNPq/MCT), Pronex Paraná, and Fundação Araucária, and FAPESP.

## References

- [1] Albouy G, Sterpenich V, Balteau E, Vandewalle G, Desseilles M, Dang-Vu T, et al. Both the hippocampus and striatum are involved in consolidation of motor sequence memory. *Neuron* 2008;85:261–72.
- [2] Alexander GE, DeLong MR, Strick PL. Parallel organization of functionally segregated circuits linking basal ganglia and cortex. *Annu Rev Neurosci* 1986;9:357–81.
- [3] Angelucci MEM, Vital MAF, Cesário C, Zadusky CR, Rosalen P, Da Cunha C. The effect of caffeine on animal models of learning and memory. *Eur J Pharmacol* 1999;373:135–40.
- [4] Aosaki T, Kimura M, Graybiel AM. Temporal and spatial characteristics of tonically active neurons of the primates striatum. *J Neurophysiol* 1995;73:1234–52.
- [5] Apicella P, Ravel S, Sardo P, Legallet E. Influence of predictive information on responses of tonically active neurons in the monkey striatum. *J Neurophysiol* 1998;80:3341–4.
- [6] Balleine BW, Delgado MR, Hikosaka O. The role of the dorsal striatum in reward and decision-making. *J Neurosci* 2007;27:8161–5.
- [7] Balleine BW, Liljeholm M, Ostlund SB. Integrative function of the basal ganglia in instrumental conditioning. *Behav Brain Res* 2008, this issue.
- [8] Bar-Gad I, Morris G, Bergman H. Information processing, dimensionality reduction and reinforcement learning in the basal ganglia. *Prog Neurobiol* 2003;71:439–73.
- [9] Barneoud P, Descombris E, Aubin N, Abrous DN. Evaluation of simple and complex sensorimotor behaviours in rats with a partial lesion of the dopaminergic nigrostriatal system. *Eur J Neurosci* 2000;12:322–36.
- [10] Bayer H, Glimcher P. Midbrain dopamine neurons encode a quantitative reward prediction error signal. *Neuron* 2005;47:129–41.
- [11] Belin D, Jonkman S, Dickinson A, Robbins TW, Everitt BJ. Parallel and interactive learning processes within the basal ganglia: relevance for the understanding of addiction. *Behav Brain Res* 2008, this issue.
- [12] Bermudez-Rattoni F, Mujica-González M, Prado-Alcala RA. Is cholinergic activity of the striatum involved in the acquisition of positively-motivated behaviors? *Pharmacol Biochem Behav* 1986;24:715–9.
- [13] Blandini F, Nappi G, Tassorelli C, Martignoni E. Functional changes of the basal ganglia circuitry in Parkinson's disease. *Prog Neurobiol* 2000;62:63–88.
- [14] Blazquez PM, Fujii N, Kojima J, Graybiel AM. A network representation of response probability in the striatum. *Neuron* 2002;33:973–82.
- [15] Bolam JP, Hanley JJ, Booth PAC, Bevan MD. Synaptic organisation of the basal ganglia. *J Anat* 2000;96:527–42.
- [16] Braga R, Kouzmine I, Canteras NS, Da Cunha C. Lesion of the substantia nigra, pars compacta impairs delayed alternation in a Y-maze in rats. *Exp Neurol* 2005;192:134–41.
- [17] Brasted PJ, Humby T, Dunnett SB, Robbins TW. Unilateral lesions of the dorsal striatum in rats disrupt responding in egocentric space. *J Neurosci* 1997;17:8919–26.
- [18] Brown VJ, Desimone R, Mishkin M. Responses of cells in the tail of the caudate nucleus during visual discrimination learning. *J Neurophysiol* 1995;74:1083–94.
- [19] Calabresi P, Maj R, Pisani A, Mercuri NB, Bernardi G. Long-term synaptic depression in the striatum: physiological and pharmacological characterization. *J Neurosci* 1992;12:4224–33.
- [20] Calabresi P, Picconi B, Tozzi A, Filippo M. Dopamine-mediated regulation of corticostriatal synaptic plasticity. *Trends Neurosci* 2007;30:211–9.
- [21] Calabresi P, Saiardi A, Pisani A, Baik JH, Centonze D, Mercuri NB, et al. Abnormal synaptic plasticity in the striatum of mice lacking dopamine D2 receptors. *J Neurosci* 1997;17:4536–44.
- [22] Calzavara R, Mailly P, Haber SN. Relationship between the corticostriatal terminals from areas 9 and 46, and those from area 8A, dorsal and rostral premotor cortex and area 24c: an anatomical substrate for cognition to action. *Eur J Neurosci* 2007;26:2005–24.
- [23] Cammarota M, Bevilacqua LRM, Kohler C, Medina JH, Izquierdo I. Learning twice is different from learning once and from learning more. *Neuroscience* 2005;132:273–9.
- [24] Castellanos FX, Giedd JN, Marsh WL, Hamburger SD, Vaituzis AC, Dickstein DP, et al. Quantitative brain magnetic resonance imaging in attention-deficit hyperactivity disorder. *Arch Gen Psychiatry* 1996;53:607–16.
- [25] Centonze D, Grande C, Saulle E, Martin AB, Gubellini P, Pavon N, et al. Distinct roles of D1 and D5 dopamine receptors in motor activity and striatal synaptic plasticity. *J Neurosci* 2003;23:8506–12.
- [26] Chang C, Crottaz-Herbette S, Menon V. Temporal dynamics of basal ganglia response and connectivity during verbal working memory. *Neuroimage* 2007;34:1253–69.
- [27] Charpier S, Deniau JM. In vivo activity-dependent plasticity at cortico-striatal connections: evidence for physiological long-term potentiation. *Proc Natl Acad Sci U S A* 1997;94:7036–40.
- [28] Cheatwood JL, Corwin JV, Reep RL. Overlap and interdigitation of cortical and thalamic afferents to dorsocentral striatum in the rat. *Brain Res* 2005;1036:90–100.
- [29] Chudler EH, Sugiyama K, Dong WK. Multisensory convergence and integration in the neostriatum and globus pallidus of the rat. *Brain Res* 1995;674:33–45.
- [30] Cohen MX, Frank MJ. Neurocomputational models of basal ganglia function in learning, memory and choice. *Behav Brain Res* 2008, this issue.
- [31] Coizet V, Comoli E, Westby GW, Redgrave P. Phasic activation of substantia nigra and the ventral tegmental area by chemical stimulation of the superior colliculus: an electrophysiological investigation in the rat. *Eur J Neurosci* 2003;17:28–40.
- [32] Coizet V, Dommert EJ, Redgrave P, Overton PG. Nociceptive responses of mid-brain dopaminergic neurones are modulated by the superior colliculus in the rat. *Neuroscience* 2006;139:1479–93.
- [33] Comoli E, Coizet V, Boyes J, Bolam JP, Canteras NS, Quirk RH, et al. A direct projection from superior colliculus to substantia nigra for detecting salient visual events. *Nat Neurosci* 2003;6:974–80.
- [34] Cromwell HC, Berridge KC. Implementation of action sequences by a neostriatal site a lesion mapping study of grooming syntax. *J Neurosci* 1996;16:3444–58.
- [35] Cromwell HC, Schultz W. Effects of expectations for different reward magnitudes on neuronal activity in primate striatum. *J Neurophysiol* 2003;89:2823–38.
- [36] Crutcher MD, DeLong MR. Single cell studies of the primate putamen. I. Functional organization. *Exp Brain Res* 1984;53:233–43.
- [37] Czubyko U, Pleniz D. Fast synaptic transmission between striatal spiny projection neurons. *Proc Natl Acad Sci U S A* 2002;99:15764–9.
- [38] Da Cunha C, Angelucci MEM, Canteras NS, Wonnacott S, Takahashi RN. The lesion of the rat substantia nigra pars compacta dopaminergic neurons as a model for Parkinson's disease memory disabilities. *Cell Mol Neurobiol* 2002;22:227–37.
- [39] Da Cunha C, Gevaerd MS, Vital MABF, Miyoshi E, Andreolini R, Silveira R, et al. Memory in rats with nigral lesion induced by MPTP: a model for early Parkinson's disease amnesia. *Behav Brain Res* 2001;124:9–18.

- [40] Da Cunha C, Silva MHC, Wietzikoski S, Wietzikoski E, Ferro MS, Kouzmine I, et al. Place learning strategy of substantia nigra pars compacta-lesioned rats. *Behav Neurosci* 2006;120:1279–84.
- [41] Da Cunha C, Wietzikoski EC, Ferro MM, Martinez GR, Vital MABF, Hipolide D, et al. Hemiparkinsonian rats rotate toward the side with the weaker dopaminergic neurotransmission. *Behav Brain Res* 2008;189:364–72.
- [42] Da Cunha C, Wietzikoski S, Wietzikoski E, Silva MHC, Chandler J, Ferro MM, et al. Pre-training to find a hidden platform in the Morris water maze can compensate for deficit to find a cued platform in a rat model of Parkinson's disease. *Neurobiol Learn Mem* 2007;87:451–63.
- [43] Da Cunha C, Wietzikoski S, Wietzikoski EC, Miyoshi E, Ferro MM, Anselmo-Franci JA, et al. Evidence for the substantia nigra pars compacta as an essential component of a memory system independent of the hippocampal memory system. *Neurobiol Learn Mem* 2003;79:236–42.
- [44] Damsma G, Pfaus JG, Wenkstern D, Phillips AG, Fibiger HC. Sexual behavior increases dopamine transmission in the nucleus accumbens and striatum of male rats: comparison with novelty and locomotion. *Behav Neurosci* 1992;106:181–91.
- [45] DeCoteau WE, Kesner RP. A double dissociation between the rat hippocampus and medial caudoputamen in processing two forms of knowledge. *Behav Neurosci* 2000;14:1096–108.
- [46] Del Guante MAD, Rivas M, Prado-Alcala RA, Quirarte GL. Amnesia produced by pre-training infusion of serotonin into the substantia nigra. *Neuroreport* 2004;15:2527–9.
- [47] Delgado MR, Nystrom LE, Fissell C, Noll DC, Fiez JA. Tracking the hemodynamic responses to reward and punishment in the striatum. *J Neurophysiol* 2000;84:3072–7.
- [48] DeLong MR, Wichmann T. Circuits and circuit disorders of the basal ganglia. *Arch Neurol* 2007;64:20–4.
- [49] Devan BD, McDonald RJ, White NM. Effects of medial and lateral caudate-putamen lesions on place- and cue-guided behaviours in the water maze: influence of thigmotaxis. *Behav Brain Res* 1999;100:5–14.
- [50] Di Filippo M, Picconi B, Barone I, Ghiglieri V, Bagetta V, Sgobio C, et al. Striatal synaptic plasticity: underlying mechanisms and implications for reward-related learning. *Behav Brain Res* 2008, this issue.
- [51] Doyon J, Bellec P, Amisler R, Penhune V, Monchi O, LeHérecy S, et al. Contributions of the basal ganglia and functionally related brain structures to motor learning. *Behav Brain Res* 2008, this issue.
- [52] Doyon J, Benali H. Reorganization and plasticity in the adult brain during learning of motor skills. *Curr Opin Neurobiol* 2005;15:161–7.
- [53] Doyon J, Laforce R, Bouchard G, Gaudreau D, Roy J, Poirier M, et al. Role of the striatum, cerebellum and frontal lobes in the automatization of a repeated visuomotor sequence of movements. *Neuropsychologia* 1998;36:625–41.
- [54] Doyon J, Ungerleider L. Functional anatomy of motor skill learning. In: Squire L, Schacter D, editors. *Neuropsychology of memory*. New York: Guilford Press; 2002, p.225–238.
- [55] Ehringer H, Hornykiewicz O. Verteilung von noradrenalin und dopamin (3-hydroxytyramin) im Gehirn des Menschen und ihr Verhalten bei Erkrankungen des extrapyramidalen system. *Klin Wochenschr* 1960;1236–9.
- [56] Eichenbaum H. *The cognitive neuroscience of memory: an introduction*. NY: Oxford University Press; 2002, 384 p.
- [57] Eschenko O, Mizumori SJY. Memory influences on hippocampal and striatal neural codes: effects of a shift between task rules. *Neurobiol Learn Mem* 2007;87:495–509.
- [58] Everitt BJ, Robbins TW. Neural systems of reinforcement for drug addiction: from actions to habits to compulsion. *Nat Neurosci* 2005;8:1481–9.
- [59] Faure A, Haberland U, Conde F, El Massioui N. Lesion to the nigrostriatal dopamine system disrupts stimulus-response habit formation. *J Neurosci* 2005;25:2771–80.
- [60] Fernandez-Ruiz J, Wang J, Aigner TG, Mishkin N. Visual habit formation in monkeys with neurotoxic lesions of the ventrocaudal neostriatum. *Proc Natl Acad Sci U S A* 2001;98:4196–201.
- [61] Ferro MM, Bellissimo MI, Anselmo-Franci JA, Angellucci E, Canteras NS, Da Cunha C. Comparison of bilaterally 6-OHDA- and MPTP lesioned rats as models of the early phase of Parkinson's Disease: histological, neurochemical, motor and memory alterations. *J Neurosci Methods* 2005;148:78–87.
- [62] Flaherty AW, Graybiel AM. Corticostriatal transformations in the primate somatosensory system—projections from physiologically mapped body-part representations. *J Neurophysiol* 1991;66:1249–63.
- [63] Flaherty AW, Graybiel AM. Input-output organization of the sensorimotor striatum in the squirrel-monkey. *J Neurosci* 1994;14:599–610.
- [64] Frank MC. Dynamic dopamine modulation in the basal ganglia: a neuro-computational account of cognitive deficits in medicated and nonmedicated parkinsonism. *J Cogn Neurosci* 2005;17:51–72.
- [65] Freeman AS. Firing properties of substantia nigra dopaminergic neurons in freely moving rats. *Life Sci* 1985;36:1983–94.
- [66] French SJ, Totterdell S. Hippocampal and prefrontal cortical inputs monosynaptically converge with individual projection neurons of the nucleus accumbens. *J Comp Neurol* 2002;446:151–65.
- [67] Fudge JL, Breitbart MA, Danish M, Pannoni V. Insular and gustatory inputs to the caudal ventral striatum in primates. *J Comp Neurol* 2005;490:101–18.
- [68] Gao DM, Nevet A, Vaadia E, Bergman H. Coincident but distinct messages of midbrain dopamine and striatal tonically active neurons. *Neuron* 2004;43:133–43.
- [69] Gao DM, Jeaugey L, Pollak P, Benabid AL. Intensity-dependent nociceptive responses from presumed dopaminergic neurons of the substantia nigra, pars compacta in the rat and their modification by lateral habenula inputs. *Brain Res* 1990;529:315–9.
- [70] Gerdeman GL, Ronesi J, Lovinger DM. Postsynaptic endocannabinoid release is critical to long-term depression in the striatum. *Nat Neurosci* 2002;446–51.
- [71] Gerfen CR, Engber TM, Mahan LC, Susel Z, Chase TN, Monsma FJ, et al. D1 and D2 dopamine receptor regulated gene-expression of striatonigral and striatopallidal neurons. *Science* 1990;250:1429–32.
- [72] Gerfen CR. Indirect-pathway neurons lose their spines in Parkinson disease. *Nat Neurosci* 2006;9:157–8.
- [73] Gevaerd MS, Miyoshi E, Silveira R, Canteras NS, Takahashi RN, Da Cunha C. Levodopa treatment restores the striatal level of dopamine but fails to reverse memory deficits in rats treated with MPTP, an animal model of Parkinson's disease. *Int J Neuropsychopharmacol* 2001;4:361–70.
- [74] Gevaerd MS, Takahashi RN, Silveira R, Da Cunha C. Caffeine reverses the memory disruption induced by intra-nigral MPTP-injection in rats. *Brain Res Bull* 2001;55:101–6.
- [75] Goto Y, Otani S, Grace AC. The Yin and Yang of dopamine release: a new perspective. *Neuropharmacology* 2007;53:583–7.
- [76] Grace AA, Bunney BS. The control of firing pattern in nigral dopamine neurons: single spike firing. *J Neurosci* 1984;4:2866–76.
- [77] Grace AA, Bunney BS. The control of firing pattern in nigral dopamine neurons: burst firing. *J Neurosci* 1984;4:2877–90.
- [78] Grahm JA, Parkinson JA, Owen AM. The role of the basal ganglia in learning and memory: neuropsychological studies. *Behav Brain Res* 2008, this issue.
- [79] Graybiel AM, Aosaki T, Flaherty AW, Kimura M. The basal ganglia and adaptive motor control. *Science* 1994;265:1826–32.
- [80] Graybiel AM. Network-level neuroplasticity in cortico-basal ganglia pathways. *Parkinsonism Relat Disord* 2004;10:293–6.
- [81] Graybiel AM, Ragsdale Jr CW. Histochemically distinct compartments in the striatum of human, monkeys and cat demonstrated by acetylthiocholinesterase staining. *Proc N Y Acad Sci U S A* 1978;75:5723–6.
- [82] Graziano MSA, Gross CG. A bimodal map of space: somatosensory receptive fields in the macaque putamen with corresponding visual receptive fields. *Exp Brain Res* 1993;97:96–109.
- [83] Grillner S, Hellgren J, Menard A, Saitoh K, Wikstrom MA. Mechanisms for selection of basic motor programs—roles for the striatum and pallidum. *Trends Neurosci* 2005;28:364–70.
- [84] Guarraci FA, Kapp BS. An electrophysiological characterization of ventral tegmental area dopaminergic neurons during differential Pavlovian fear conditioning in the awake rabbit. *Behav Brain Res* 1999;99:169–79.
- [85] Guillazo-Blanch G, Nadal R, Vale-Martinez A, Mart'ı-Nicolovius M, Ar'evalo R, Morgado-Bernal I. Effects of fimbria lesions on trace two-way active avoidance acquisition and retention in rats. *Neurobiol Learn Mem* 2002;78:407–25.
- [86] Gurney K, Prescott TJ, Wickens JR, Redgrave P. Computational models of the basal ganglia: from robots to membranes. *Trends Neurosci* 2004;27:453–9.
- [87] Haber SN, Kim KS, Maily P, Calzavara R. Reward-related cortical inputs define a large striatal region in primates that interface with associative cortical inputs, providing a substrate for incentive-based learning. *J Neurosci* 2006;26:8368–76.
- [88] Harting JK, Updyke BV, Van Lieshout DP. Striatal projections from the cat visual thalamus. *Eur J Neurosci* 2001;14:893–6.
- [89] Harting JK, Updyke BV, Van Lieshout DP. The visual-oculomotor striatum of the cat: functional relationship to the superior colliculus. *Exp Brain Res* 2001;136:138–42.
- [90] Haruno M, Kawato M. Different neural correlates of reward expectation and reward expectation error in the putamen and caudate nucleus during stimulus-action-reward association learning. *J Neurophysiol* 2006;95:948–59.
- [91] Haruno M, Kuroda T, Doya K, Toyama K, Kimura M, Samejima K, et al. A neural correlate of reward-based behavioral learning in caudate nucleus: a functional magnetic resonance imaging study of a stochastic decision task. *J Neurosci* 2004;24:1660–5.
- [92] Hassani OK, Cromwell HC, Schultz W. Influence of expectation of different rewards on behavior-related neuronal activity in the striatum. *J Neurophysiol* 2001;85:2477–89.
- [93] Heckers S. Neuropathology of schizophrenia: cortex, thalamus, basal ganglia, and neurotransmitter-specific projection systems. *Schizophr Bull* 1997;23:403–21.
- [94] Herrnstein RJ. On the law of effect. *J Exp Anal Behav* 1970;13:243–66.
- [95] Hikosaka O, Nakamura K, Sakai K, Nakahara H. Central mechanisms of motor skill learning. *Curr Opin Neurobiol* 2002;12:217–22.
- [96] Hikosaka O, Sakamoto M, Usui S. Functional properties of monkey caudate neurons. II. Visual and auditory responses. *J Neurophysiol* 1989;61:799–813.
- [97] Hollerman JR, Tremblay L, Schultz W. Influence of reward expectation on behavior-related neuronal activity in primate striatum. *J Neurophysiol* 1998;80:947–63.
- [98] Hommer DW, Bunney BS. Effect of sensory stimuli on the activity of dopaminergic neurons: involvement of non-dopaminergic nigral neurons and striato-nigral pathways. *Life Sci* 1980;27:377–86.

- [99] Horvitz JC, Stewart T, Jacobs BL. Burst activity of ventral tegmental dopamine neurons is elicited by sensory stimuli in the awake cat. *Brain Res* 1997;759:251–8.
- [100] Horvitz JC. Mesolimbocortical and nigrostriatal dopamine responses to salient non-reward events. *Neuroscience* 2000;96:651–6.
- [101] Horvitz JC. Stimulus-response and response-outcome learning mechanisms in the striatum. *Behav Brain Res* 2008, this issue.
- [102] Humphries MD, Stewart RD, Gurney KN. A physiologically plausible model of action selection and oscillatory activity in the basal ganglia. *J Neurosci* 2006;26:12921–42.
- [103] Jaber M, Robinson SW, Missale C, Caron MG. Dopamine receptors and brain function. *Neuropharmacology* 1996;35:1503–19.
- [104] Jiang H, Stein BE, McHaffie JG. Opposing basal ganglia processes shape midbrain visuomotor activity bilaterally. *Nature* 2003;424:982–6.
- [105] Joel D, Weiner I. The connections of the dopaminergic system with the striatum in rats and primates: an analysis with respect to the functional and compartmental organization of the striatum. *Neuroscience* 2000;96:451–74.
- [106] Jog MS, Kubota Y, Connolly CI, Hillegaart V, Graybiel AM. Building neural representations of habits. *Science* 1999;286:1745–9.
- [107] Kawaguchi Y, Emson PC. Striatal interneurons: chemical, physiological and morphological characterization. *Trends Neurosci* 1995;18:527–35.
- [108] Kim YB, Huh N, Lee H, Baeg EH, Lee D, Jung MW. Encoding of action history in the rat ventral striatum. *J Neurophysiol* 2007;98:3548–56.
- [109] Kimura M. Role of the basal ganglia in behavioral learning. *Neurosci Res* 1995;2:353–8.
- [110] Kirkby RJ, Polgar S. Active avoidance in laboratory rat following lesions of dorsal or ventral caudate-nucleus. *Physiol Psychol* 1974;2:301–6.
- [111] Knierim JJ. Neural representations of location outside the hippocampus. *Learn Mem* 2006;13:405–15.
- [112] Knowlton BJ, Mangels JA, Squire LR. A neostriatal habit learning system in humans. *Science* 1996;273:1399–402.
- [113] Knutson B, Fong GW, Adams CM, Varner JL, Hommer D. Dissociation of reward anticipation and outcome with event-related fMRI. *Neuroreport* 2001;12:3683–7.
- [114] Lau B, Glimcher PW. Action and outcome encoding in the primate caudate nucleus. *J Neurosci* 2007;14:502–14.
- [115] Lauwereyns J, Watanabe K, Coe B, Hikosaka O. A neural correlate of response bias in monkey caudate nucleus. *Nature* 2002;418:413–7.
- [116] Lawrence AD, Watkins LHA, Sahakian BJ, Hodges JR, Robbins TW. Visual object and visuospatial cognition in Huntington's disease: implications for information processing in corticostriatal circuits. *Brain* 2000;23:1349–64.
- [117] Legault M, Wise RA. Novelty-evoked elevations of nucleus accumbens dopamine: dependence on impulse flow from the ventral subiculum and glutamatergic neurotransmission in the ventral tegmental area. *Eur J Neurosci* 2001;13:819–28.
- [118] Ljungberg T, Apicella P, Schultz W. Responses of monkey dopamine neurons during learning of behavioural reactions. *J Neurophysiol* 1992;67:145–63.
- [119] Lodge DJ, Grace AA. The hippocampus modulates dopamine neuron responsiveness by regulating the intensity of phasic neuron activation. *Neuropsychopharmacology* 2006;31:1356–61.
- [120] Lovinger DM, Tyler EC, Merritt A. Short- and long-term synaptic depression in rat neostriatum. *J Neurophysiol* 1993;70:1937–49.
- [121] Lynd-Balta E, Haber SN. The organization of midbrain projections to the striatum in the primate: sensorimotor-related striatum versus ventral striatum. *Neuroscience* 1994;59:625–40.
- [122] Maeda H, Mogenson GJ. Effects of peripheral stimulation on the activity of neurons in the ventral tegmental area, substantia nigra and midbrain reticular formation of rats. *Brain Res Bull* 1982;8:7–14.
- [123] Malach R, Graybiel AM. Mosaic architecture of the somatic sensory-recipient sector of the cat's striatum. *J Neurosci* 1986;6:3436–58.
- [124] Malenka RC, Nicoll RA. Neuroscience—long-term potentiation—a decade of progress? *Science* 1999;285:1870–4.
- [125] Mantz J, Thierry AM, Glowinski J. Effect of noxious tail pinch on the discharge rate of mesocortical and mesolimbic dopamine neurons: selective activation of the mesocortical system. *Brain Res* 1989;476:377–81.
- [126] Martin PD, Ono T. Effects of reward anticipation, reward presentation, and spatial parameters on the firing of single neurons recorded in the subiculum and nucleus accumbens of freely moving rats. *Behav Brain Res* 2000;116:23–38.
- [127] Martone M, Bytters N, Payne P, Becker JT, Sax DS. Dissociation between skill learning and verbal recognition in amnesia and dementia. *Arch Neurol* 1984;41:965–70.
- [128] McDonald RJ, White NM. Hippocampal and non-hippocampal contributions to place learning. *Behav Neurosci* 1995;109:579–93.
- [129] McGeorge AJ, Faull RLM. The organization of the projection from the cerebral cortex to the striatum in the rat. *Neuroscience* 1989;29:503–38.
- [130] McHaffie JG, Thomson CM, Stein BE. Corticotectal and corticostriatal projections from the frontal eye fields of the cat: an anatomical examination using WGA-HRP. *Somatosen Mot Res* 2001;18:117–30.
- [131] McHaffie JG, Stanford TR, Stein BE, Coizet V, Redgrave P. Subcortical loops through the basal ganglia. *Trends Neurosci* 2005;28:401–7.
- [132] McNab F, Klingberg T. Prefrontal cortex and basal ganglia control access to working memory. *Nat Neurosci* 2008;11:103–7.
- [133] Medina AC, Charles JR, Espinoza-Gonzalez V, Sanchez-Resendis O, Prado-Alcala RA, Rozenzdaal B, et al. Glucocorticoid administration into the dorsal striatum facilitates memory consolidation of inhibitory avoidance training but not of the context or footshock components. *Learn Mem* 2007;14:673–8.
- [134] Middleton FA, Strick PL. The temporal lobe is a target of output from the basal ganglia. *Proc Natl Acad Sci USA* 1996;93:8683–7.
- [135] Mink JW. The basal ganglia: focused selection and inhibition of competing motor programs. *Prog Neurobiol* 1996;50:381–425.
- [136] Mishkin M, Petri HL. Memories and habits: some implications for the analysis of learning retention. In: Squire RL, Butters N, editors. *The neuropsychology of memory*. New York: Gilford Press; 1984. p. 187–96.
- [137] Mitchell JA, Hall G. Caudate-putamen lesions may impair or potentiate maze learning depending upon availability of stimulus cues and relevance of response cues. *Quart J Exp Psychol* 1988;40B:243–58.
- [138] Miyoshi E, Wietzikoski S, Camplesse M, Silveira R, Takahashi EN, Da Cunha C. Impaired learning in a spatial working memory version and in a cued version of the water maze in rats with MPTP-induced mesencephalic dopaminergic lesion. *Brain Res Bull* 2002;58:41–7.
- [139] Mizumori SJ, Puryear CB, Martig AK. Basal ganglia. Contributions to adaptive navigation. *Behav Brain Res* 2008, this issue.
- [140] Mizumori SJY, Ragozzino KE, Cooper BG. Location and head direction representation in the dorsal striatum of rats. *Psychobiology* 2000;28:441–62.
- [141] Mizumori SJY, Yeshenko O, Gill KM, Davis DM. Parallel processing across neural systems: implications for a multiple memory system hypothesis. *Neurobiol Learn Mem* 2004;82:278–98.
- [142] Montoya A, Price BH, Menear M, Lepage M. Brain imaging and cognitive dysfunctions in Huntington's disease. *J Psychiatry Neurosci* 2006;31:21–9.
- [143] Morris G, Arkadir D, Nevet A, Vaadia E, Bergman H. Coincident but distinct messages of midbrain dopamine and striatal tonically active neurons. *Neuron* 2004;43:133–43.
- [144] Morris G, Nevet A, Bergman H. Anatomical funneling, sparse connectivity and redundancy reduction in the neural networks of the basal ganglia. *J Physiol* 2003;97:581–9.
- [145] Mulder AB, Tabuchi E, Wiener SI. Neurons in hippocampal afferent zones of rat striatum parse routes into multi-pace segments during maze navigation. *Eur J Neurosci* 2004;19:1923–32.
- [146] Nagy A, Eordeghe G, Norita M, Benedek G. Visual receptive field properties of neurons in the caudate nucleus. *Eur J Neurosci* 2003;18:449–52.
- [147] Nagy A, Eordeghe G, Paroczy Z, Markus Z, Benedek G. Multisensory integration in the basal ganglia. *Eur J Neurosci* 2006;24:917–24.
- [148] Nagy A, Paroczy Z, Norita M, Benedek G. Multisensory responses and receptive field properties of neurons in the substantia nigra and in the caudate nucleus. *Eur J Neurosci* 2005;22:419–24.
- [149] Nicola SM. The nucleus accumbens as part of a basal ganglia action selection circuit. *Psychopharmacology* 2007;191:521–50.
- [150] Niida T, Stein BE, McHaffie JG. Response properties of corticotectal and corticostriatal neurons in the posterior lateral suprasylvian cortex of the cat. *J Neurosci* 1997;17:8550–65.
- [151] Nirenberg MJ, Chan J, Pohorille A, Vaughan RA, Uhl GR, Kuhar MJ, et al. The dopamine transporter: comparative ultrastructure of dopaminergic axons in limbic and motor compartments of the nucleus accumbens. *J Neurosci* 1997;17:6899–907.
- [152] O'Doherty J, Dayan P, Schultz J, Deichmann R, Friston K, Dolan RJ. Dissociable roles of ventral and dorsal striatum in instrumental conditioning. *Science* 2004;304:452–4.
- [153] O'Keefe J, Nadel L. *The hippocampus as a cognitive map*. Oxford, England: Oxford University Press; 1978, 570 pp.
- [154] O'Reilly RC, Frank MJ. Making working memory work: a computational model of learning in the prefrontal cortex and basal ganglia. *Neural Comput* 2006;18:283–328.
- [155] Owen AM. Cognitive dysfunction in Parkinson disease: the role of frontostriatal circuitry. *Neuroscientist* 2004;10:525–37.
- [156] Packard MG, Cahill L, McGaugh JL. Amygdala modulation of hippocampal-dependent and caudate nucleus-dependent memory processes. *Proc Natl Acad Sci USA* 1994;91:8477–81.
- [157] Packard MG, Hirsh R, White NM. Differential roles of the hippocampus and caudate nucleus lesion on two radial maze tasks: evidence for multiple memory systems. *J Neurosci* 1989;9:1465–72.
- [158] Packard MG, Knowlton BJ. Learning and memory functions of the basal ganglia. *Annu Rev Neurosci* 2002;25:563–93.
- [159] Packard MG, McGaugh JL. Double dissociation of fornix and caudate nucleus lesions on acquisition of two water maze tasks: further evidence for multiple memory systems. *Behav Neurosci* 1992;106:439–46.
- [160] Packard MG, McGaugh JL. Inactivation of hippocampus or caudate nucleus with lidocaine differentially affects expression of place and response learning. *Neurobiol Learn Mem* 1996;65:66–72.
- [161] Packard MG, White NM. Dissociation of hippocampal and caudate nucleus memory systems by post-training intracerebral injection of dopamine agonists. *Behav Neurosci* 1991;105:295–306.
- [162] Packard MG, White NM. Lesions of the caudate nucleus selectively impair acquisition of "reference memory" in the radial maze. *Behav Neural Biol* 1990;53:39–50.
- [163] Parent A, Hazrati LN. Functional anatomy of the basal ganglia. I. The cortico-basal ganglia-thalamo-cortical loop. *Brain Res* 1995;20:91–127.
- [164] Parkinson J. *An essay on the sacking plasy*. Shewood: Neely and Jones; 1817.



- [165] Perez-Ruiz C, Prado-Alcala RA. Retrograde amnesia induced by lidocaine injection into the striatum: protective effect of the negative reinforcer. *Brain Res Bull* 1989;22:599–603.
- [166] Pisani A, Bernardi G, Ding J, Surmeier DJ. Re-emergence of striatal cholinergic interneurons in movement disorders. *Trends Neurosci* 2007;30(10):545–53.
- [167] Pouderoux C, Freton E. Patterns of unit responses to visual stimuli in the cat caudate nucleus under chloralose anesthesia. *Neurosci Lett* 1979;11:53–8.
- [168] Prado-Alcala RA, Grinberg ZJ, Alvarez-Leefmans FJ, Brust-Carmona H. Suppression of motor conditioning by the injection of 3 M KCl in the caudate nuclei of cats. *Physiol Behav* 1973;10:59–64.
- [169] Prado-Alcala RA, Grinberg ZJ, Alvarez-Leefmans FJ, Gomez A, Singer S, Brust-Carmona H. A possible caudate-cholinergic mechanism in two instrumental conditioned responses. *Psychopharmacologia (Berl)* 1972;25:339–46.
- [170] Prado-Alcala RA, Grinberg ZJ, Arditti ZL, Garcia MM, Prieto HG, Brust-Carmona H. Learning deficits produced by chronic and reversible lesions of the corpus striatum in rats. *Physiol Behav* 1975;15:283–7.
- [171] Prado-Alcala RA, Solana-Figueroa R, Galindo LE, Medina AC, Quirarte GL. Blockade of striatal 5-HT<sub>2</sub> receptors produces retrograde amnesia in rats. *Life Sci* 2003;74:481–8.
- [172] Ragozzino KE, Leutgeb S, Mizumori SJY. Conditional coupling of dorsal striatal head direction and hippocampal place representations during spatial navigation. *Exp Brain Res* 2001;139:372–6.
- [173] Redgrave P, Gurney K, Reynolds J. What is reinforced by phasic dopamine signals? *Brain Res Rev* 2008;58:322–39.
- [174] Redgrave P, Prescott T, Gurney KN. The basal ganglia: a vertebrate solution to the selection problem. *Neuroscience* 1999;89:1009–23.
- [175] Reep RL, Cheatwood JL, Corwin JV. The associative striatum: organization of cortical projections to the dorsocentral striatum in rats. *J Comp Neurol* 2003;467:271–92.
- [176] Rolls ET, Thorpe SJ, Maddison SP. Responses of striatal neurons in the behaving monkey. 1. Head of the caudate nucleus. *Behav Brain Res* 1983;7:179–210.
- [177] Romanelli P, Esposito V, Schaal DW, Heit G. Somatotopy in the basal ganglia: experimental and clinical evidence for segregated sensorimotor channels. *Brain Res Rev* 2005;48:112–28.
- [178] Roncacci S, Troisi E, Carlesimo GA, Nocentini U, Caltagirone C. Implicit memory in Parkinsonian patients: evidence for deficient skill learning. *Eur Neurol* 1996;36:154–9.
- [179] Rosell A, Gimenez-Amaya JM. Anatomical re-evaluation of the corticostriatal projections to the caudate nucleus: a retrograde labeling study in the cat. *Neurosci Res* 1999;34:257–69.
- [180] Sagvolden T, Johnsrud G. Two-way active avoidance learning following medial, dorsolateral, or total septal lesions in rats: effect of intensity of discontinuous shock. *Behav Neural Biol* 1982;35:17–32.
- [181] Salado-Castillo R, Diaz del Guante MA, Alvarado R, Quirarte GL, Prado-Alcala RA. Effects of regional GABAergic blockade of the striatum on memory consolidation. *Neurobiol Learn Mem* 1996;66:102–8.
- [182] Salmon DP, Butters N. Neurobiology of skill and habit learning. *Curr Opin Neurobiol* 1995;5:184–90.
- [183] Santos LM, Ferro MM, Mota-Ortiz SR, Baldo MV, Da Cunha C, Canteras NS. Effects of ventrolateral striatal inactivation on predatory hunting. *Physiol Behav* 2007;90:669–73.
- [184] Schneider JS. Responses of striatal neurons to peripheral sensory stimulation in symptomatic MPTP-exposed cats. *Brain Res* 1991;544:297–302.
- [185] Schonberg T, Daw ND, Joel D, O'Doherty JP. Reinforcement learning signals in the human striatum distinguish learners from nonlearners during reward-based decision making. *J Neurosci* 2007;12:860–7.
- [186] Schultz W, Dayan P, Montague PR. A neural substrate of prediction and reward. *Science* 1997;275:1593–9.
- [187] Schultz W. Multiple dopamine functions at different time courses. *Annu Rev Neurosci* 2007;30:259–88.
- [188] Schultz W. Predictive reward signal of dopamine neurons. *J Neurophysiol* 1998;80:1–27.
- [189] Schwarting RKW. Rodent models of serial reaction time tasks and their implementation in neurobiological research. *Behav Brain Res* 2008, this issue.
- [190] Scoville WB, Milner B. Loss of recent memory after bilateral hippocampal lesions. *J Neurol Neurosurg Psychiatr* 1957;20:11–21.
- [191] Seger CA. How do the basal ganglia contribute to categorization? Their roles in generalization, response selection, and learning via feedback. *Neurosci Biobehav Rev* 2008;32:265–78.
- [192] Selemon LD, Goldman-Rakic PS. Longitudinal topography and interdigitation of corticostriatal projections in the rhesus monkey. *J Neurosci* 1985;5:776–94.
- [193] Setlow B, Schoenbaum G, Gallagher M. Neural encoding in ventral striatum during olfactory discrimination learning. *Neuron* 2003;38:625–36.
- [194] Shibata R, Mulder AB, Trullier O, Wiener SI. Position sensitivity in phasically discharging nucleus accumbens neurons of rats alternating between tasks requiring complementary types of spatial cues. *Neuroscience* 2001;108:391–411.
- [195] Shimo Y, Hikosaka O. Role of tonically active neurons in primate caudate in reward-oriented saccadic eye movement. *J Neurosci* 2001;21:7804–14.
- [196] Squire LR. Memory systems of the brain: a brief history and current perspective. *Neurobiol Learn Mem* 2004;82:171–7.
- [197] Stern EA, Kincaid AE, Wilson CJ. Spontaneous subthreshold membrane potential fluctuations and action potential variability of rat corticostriatal and striatal neurons in vivo. *J Neurophysiol* 1997;77:1697–715.
- [198] Suaud-Chagny MF, Dugast C, Chergui K, Mghina M, Gonon F. Uptake of dopamine released by impulse flow in the rat mesolimbic and striatal systems in vivo. *J Neurochem* 1995;65:2603–11.
- [199] Surmeier DJ, Song WJ, Yan Z. Coordinated expression of dopamine receptors in neostriatal MSNs. *J Neurosci* 1996;16:6579–91.
- [200] Teng E, Stefanacci L, Squire LR, Zola SM. Contrasting effects on discrimination learning after hippocampal lesions and conjoint hippocampal-caudate lesions in monkeys. *J Neurosci* 2000;20:3853–63.
- [201] Tepper JM, Bolam JP. Functional diversity and specificity of neostriatal interneurons. *Curr Opin Neurobiol* 2004;14:685–92.
- [202] Thierry AM, Gioanni Y, Dégenétais E, Glowinski J. Hippocampo-prefrontal cortex pathway: anatomical and electrophysiological characteristics. *Hippocampus* 2000;10:411–9.
- [203] Thompson WG, Guilford MO, Hicks LH. Effects of caudate and cortical lesions on place and response learning in rats. *Physiol Psychol* 1980;8:473–9.
- [204] Thorndike EL. *Animal Intelligence*. New York: Macmillan; 1911.
- [205] Tiedey JW, Miczek KA. Social defeat stress selectively alters mesocorticolimbic dopamine release: An in vivo microdialysis study. *Brain Res* 1996;72:140–9.
- [206] Torres-Garcia M, Costa-Miserachs D, Morgado-Bernal I, Portell-Cortés I. Improvement of shuttle-box performance by anterodorsal medial septal lesions in rats. *Behav Brain Res* 2003;141:147–58.
- [207] Tremblay L, Hollerman JR, Schultz W. Modifications of reward expectation-related neuronal activity during learning in primate striatum. *J Neurophysiol* 1998;80:964–77.
- [208] Tsai C-T, Nakamura S, Iwama K. Inhibition of neuronal activity of the substantia nigra by noxious stimuli and its modification by the caudate nucleus. *Brain Res* 1980;195:299–311.
- [209] Tunstall MJ, Oorschot DE, Kean A, Wickens JR. Inhibitory interactions between spiny projection neurons in the rat striatum. *J Neurophysiol* 2002;88:1263–9.
- [210] Ungless MA, Magill PJ, Bolam JP. Uniform inhibition of dopamine neurons in the ventral tegmental area by aversive stimuli. *Science* 2004;303:2040–2.
- [211] Walsh JP. Depression of excitatory synaptic input in rat striatal neurons. *Brain Res* 1993;123–8.
- [212] Webster MJ, Bachevalier J, Ungerleider LG. Subcortical connections of inferior temporal areas TE and TEO in macaque monkeys. *J Compar Neurol* 1993;335:73–91.
- [213] Weiner SI. Spatial and behavioral correlates of striatal neurons in rats performing a self-initiated navigation task. *J Neurosci* 1993;13:3802–17.
- [214] White NM, McDonald RJ. Multiple parallel memory systems in the brain of the rat. *Neurobiol Learn Mem* 2002;77:125–84.
- [215] Wickens J. *A theory of the striatum*. Oxford: Pergamon; 1993.
- [216] Wickens JR, Budd CS, Hyland BI, Arbutnot GW. Striatal contributions to reward and decision making. Making sense of regional variations in a re-iterated processing matrix. *Ann NY Acad Sci* 2007;1104:192–212.
- [217] Wickens JR, Reynolds JNJ, Hyland BI. Neural mechanisms of reward-related motor learning. *Curr Opin Neurobiol* 2003;13:685–90.
- [218] Wickens JR. Synaptic plasticity in the corticostriatal pathway. *Behav Brain Res* 2008, this issue.
- [219] Williams ZM, Eskandar EN. Selective enhancement of associative learning by microstimulation of the anterior caudate. *Nat Neurosci* 2006;9:562–8.
- [220] Wilson CJ, Kawaguchi Y. The origins of two-state spontaneous membrane potential fluctuations of neostriatal spiny neurons. *J Neurosci* 1996;16:2397–410.
- [221] Yeterian EH, Pandya DN. Corticostriatal connections of the superior temporal region in rhesus monkeys. *J Compar Neurol* 1998;399:384–402.
- [222] Yin HH, Knowlton BJ. The role of the basal ganglia in habit formation. *Nat Rev Neurosci* 2006;7:464–76.
- [223] Young AMJ. Increased extracellular dopamine in nucleus accumbens in response to unconditioned and conditioned aversive stimuli: studies using 1 min microdialysis in rats. *J Neurosci Methods* 2004;138:57–63.
- [224] Zheng T, Wilson CJ. Corticostriatal combinatorics: the implications of corticostriatal axonal arborizations. *J Neurophysiol* 2002;87:1007–17.
- [225] Zhou FM, Wilson C, Dani JA. Muscarinic and nicotinic cholinergic mechanisms in the mesostriatal dopamine systems. *Neuroscientist* 2003;9:23–36.

# Livros Grátis

( <http://www.livrosgratis.com.br> )

Milhares de Livros para Download:

[Baixar livros de Administração](#)

[Baixar livros de Agronomia](#)

[Baixar livros de Arquitetura](#)

[Baixar livros de Artes](#)

[Baixar livros de Astronomia](#)

[Baixar livros de Biologia Geral](#)

[Baixar livros de Ciência da Computação](#)

[Baixar livros de Ciência da Informação](#)

[Baixar livros de Ciência Política](#)

[Baixar livros de Ciências da Saúde](#)

[Baixar livros de Comunicação](#)

[Baixar livros do Conselho Nacional de Educação - CNE](#)

[Baixar livros de Defesa civil](#)

[Baixar livros de Direito](#)

[Baixar livros de Direitos humanos](#)

[Baixar livros de Economia](#)

[Baixar livros de Economia Doméstica](#)

[Baixar livros de Educação](#)

[Baixar livros de Educação - Trânsito](#)

[Baixar livros de Educação Física](#)

[Baixar livros de Engenharia Aeroespacial](#)

[Baixar livros de Farmácia](#)

[Baixar livros de Filosofia](#)

[Baixar livros de Física](#)

[Baixar livros de Geociências](#)

[Baixar livros de Geografia](#)

[Baixar livros de História](#)

[Baixar livros de Línguas](#)

[Baixar livros de Literatura](#)  
[Baixar livros de Literatura de Cordel](#)  
[Baixar livros de Literatura Infantil](#)  
[Baixar livros de Matemática](#)  
[Baixar livros de Medicina](#)  
[Baixar livros de Medicina Veterinária](#)  
[Baixar livros de Meio Ambiente](#)  
[Baixar livros de Meteorologia](#)  
[Baixar Monografias e TCC](#)  
[Baixar livros Multidisciplinar](#)  
[Baixar livros de Música](#)  
[Baixar livros de Psicologia](#)  
[Baixar livros de Química](#)  
[Baixar livros de Saúde Coletiva](#)  
[Baixar livros de Serviço Social](#)  
[Baixar livros de Sociologia](#)  
[Baixar livros de Teologia](#)  
[Baixar livros de Trabalho](#)  
[Baixar livros de Turismo](#)